



ASU – COLLEGE AVENUE COMMONS
 FURNITURE RFP
 FURNITURE PLANS

04.01.13

GENERAL NOTES

- IMAGES OF PRODUCTS SHOWN IN THIS DOCUMENT ARE EXAMPLES OF QUALITY AND DESIGN. USE THE COHESION OF DESIGN ESTHETIC TO PROVIDE PRODUCT SUBSTITUTES
- SEE SUMMARY DOCUMENT FOR PRODUCT QUANTITY AND TO PROVIDED TO LIST ALTERNATE PRODUCTS & INFORMATION
- SEE SPEC FOR PRODUCT INFORMATION



CH5/TL3

TS1

L2



CH5



TL3



TS1



L1

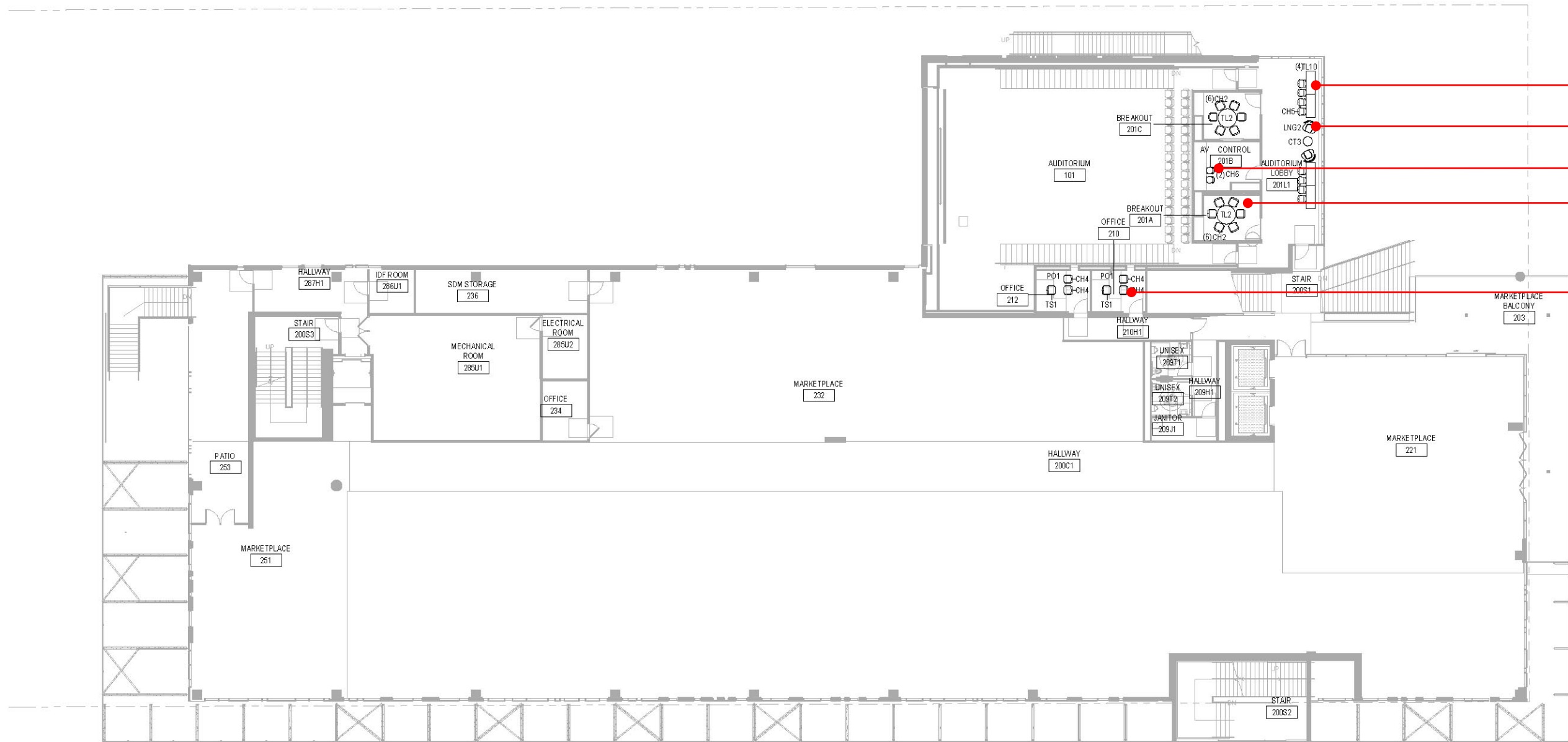

- TL10/CH5
- CT3/LNG2
- CH6
- TL2/CH2
- TS1/CH4

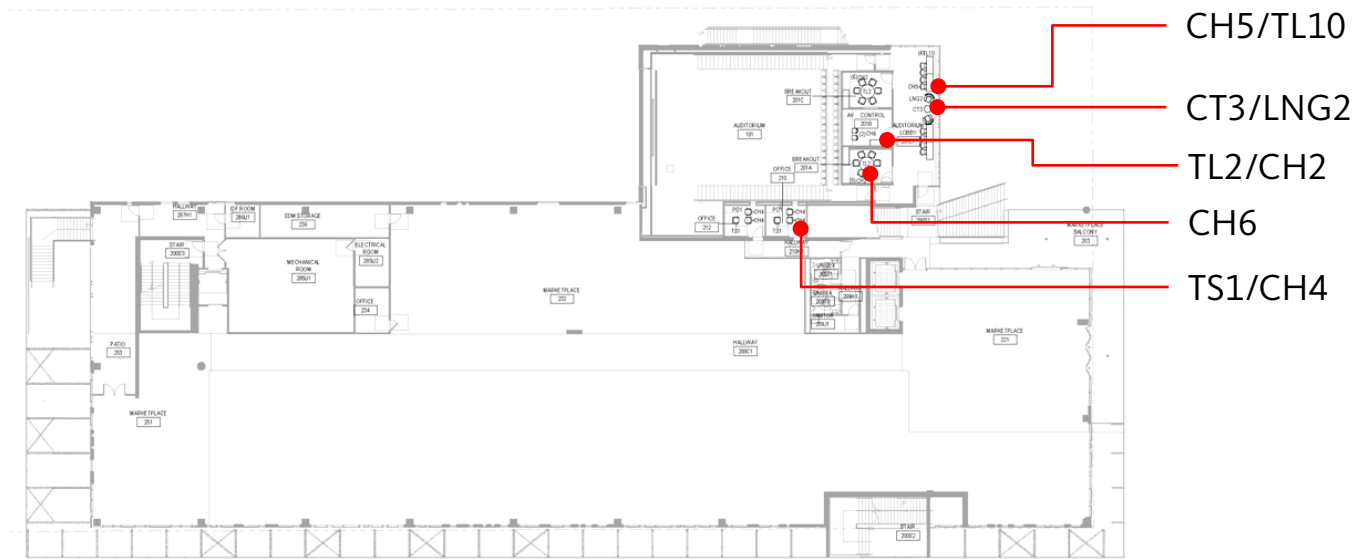

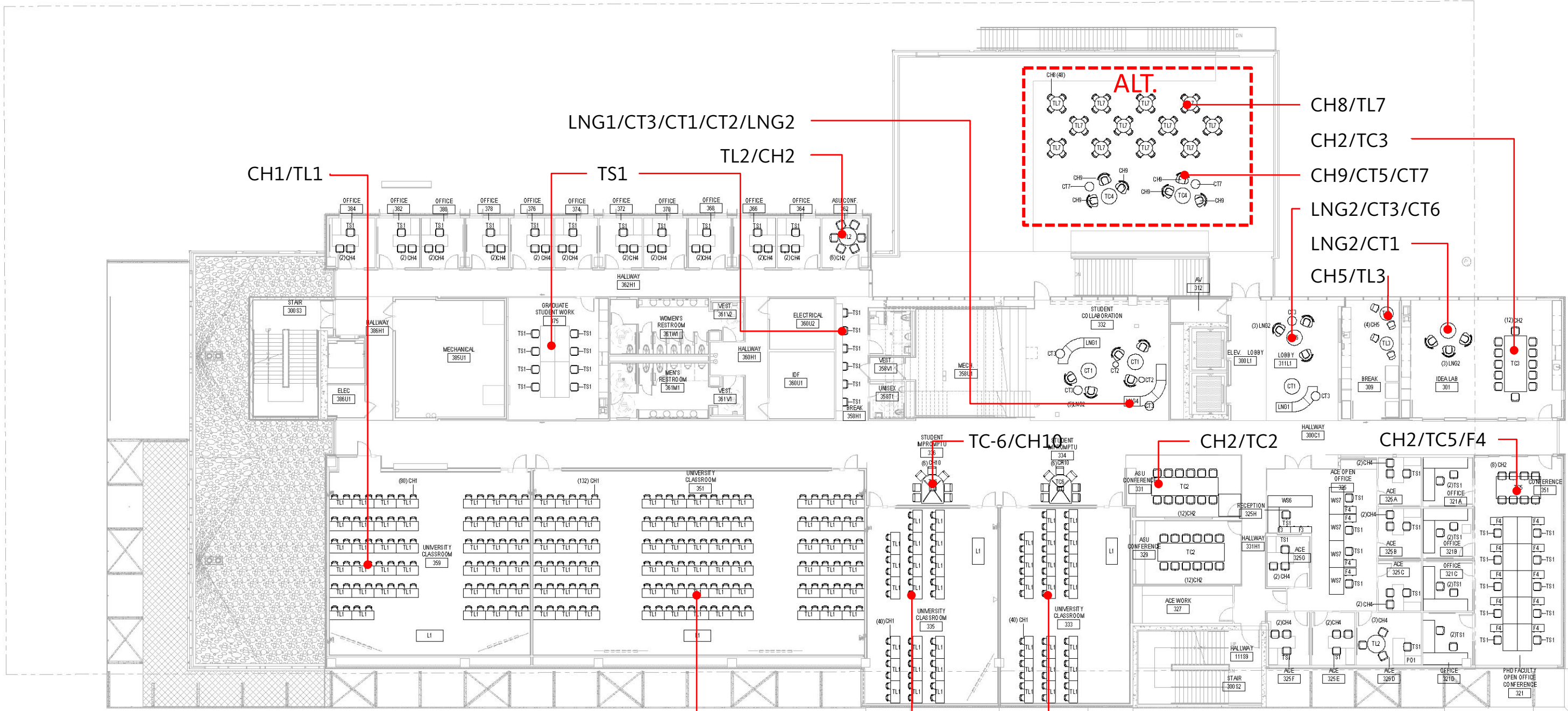

LNG1/CT3/CT1/CT2/LNG2

TL2/CH2

TS1

ALT. CH8/TL7

ALT. CT7/CT6/CH9

CH5/TL3

LNG2/CT1

CH2/TC3

LNG2/CT3/CT6 LNG1/CT1

CH2/TC5/F4

CH2/TC2

TC6/CH10

TL1/CH1

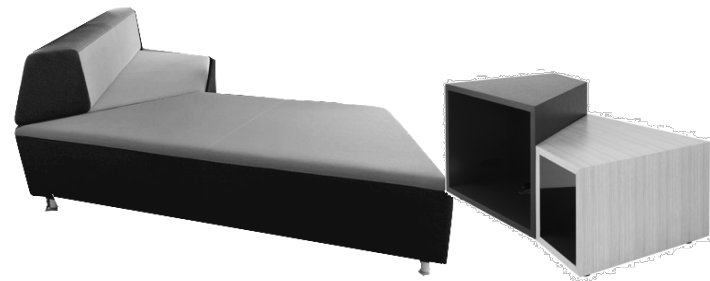
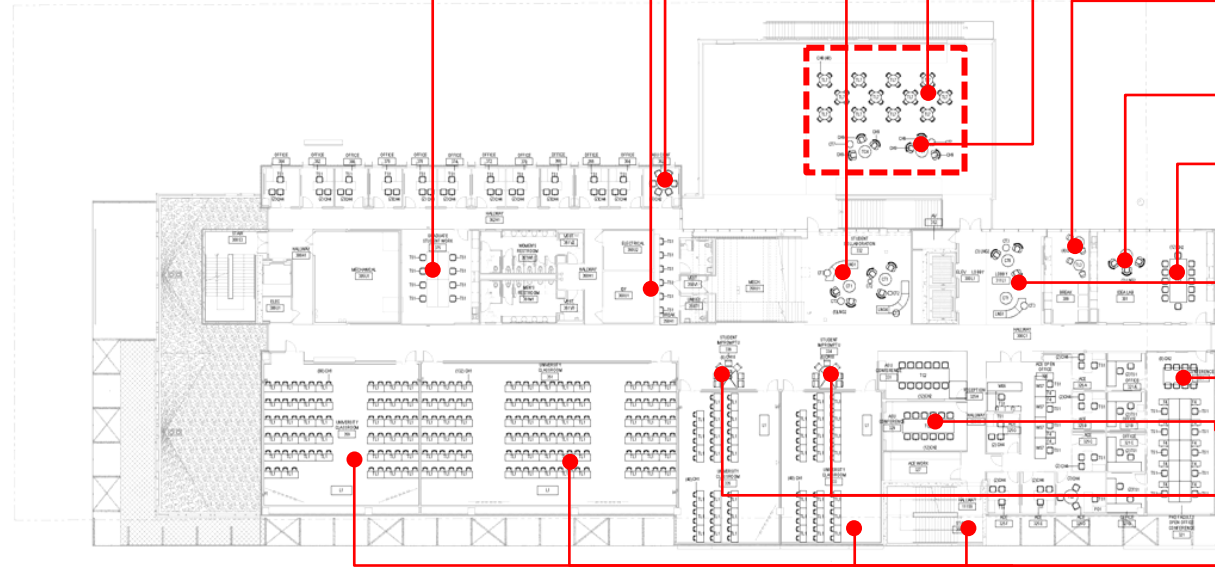

LGN1

CT1



CT2(16'')



CT3 (18'')



LNG2



TL2



CH2



TS1



CH5



TL3



CH2



TC2/TC3/TC7



CT6



F4



CH10

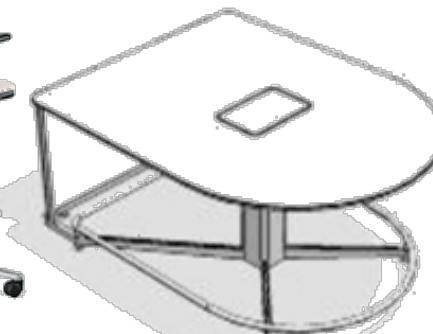

TC6

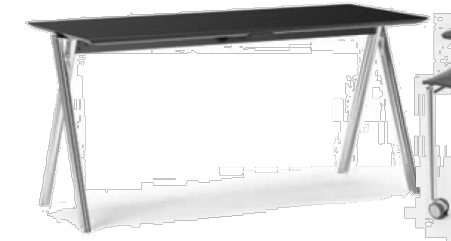

TL1



CH1

LOOSE ITEM FURNISHING

Level 03

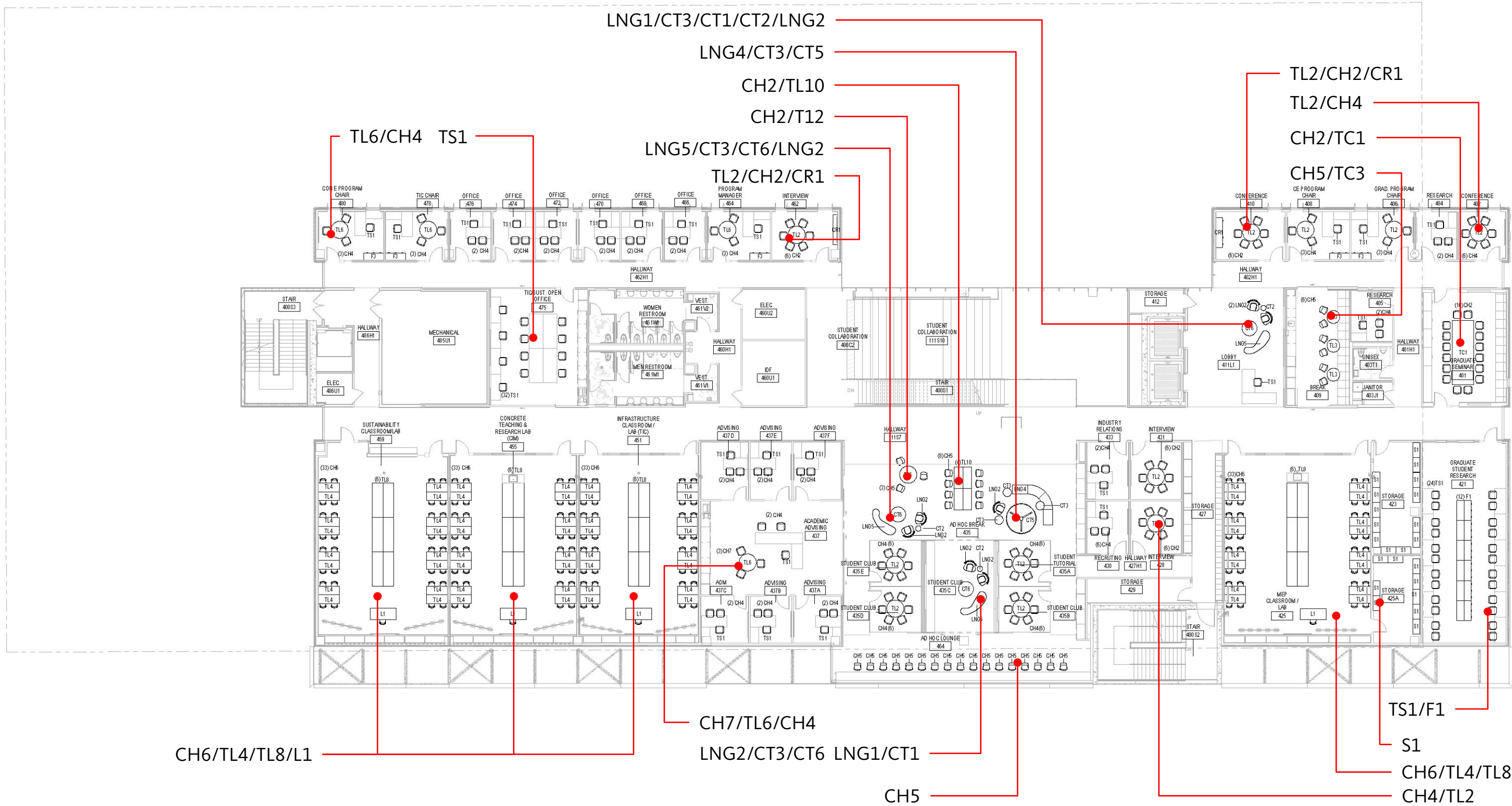

LOOSE ITEM FURNISHING

Level 04

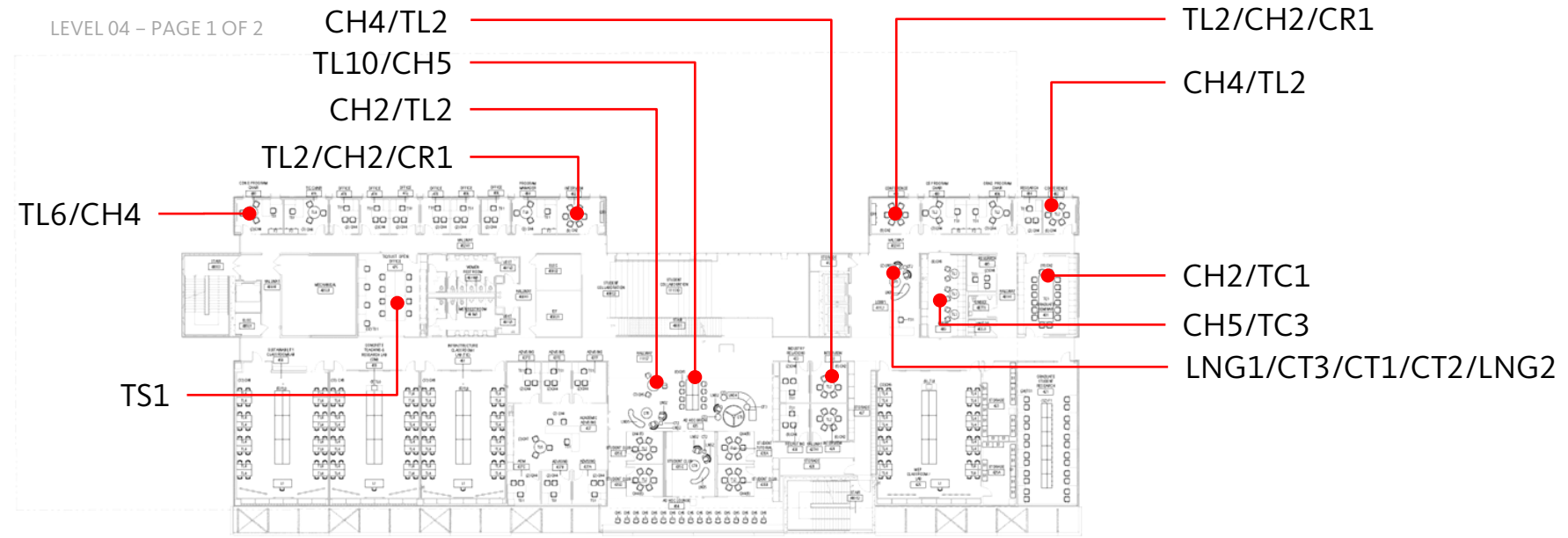

CH4



TL2



TL10



CH5



CH2



TL2



CR1



CH2



TC1



CH5



TL3

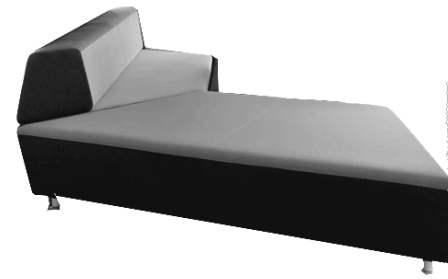

LGN1

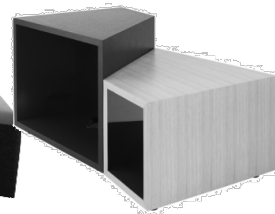

CT1



CT2(16")

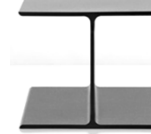

CT3 (18")



LNG2



TS1



F1

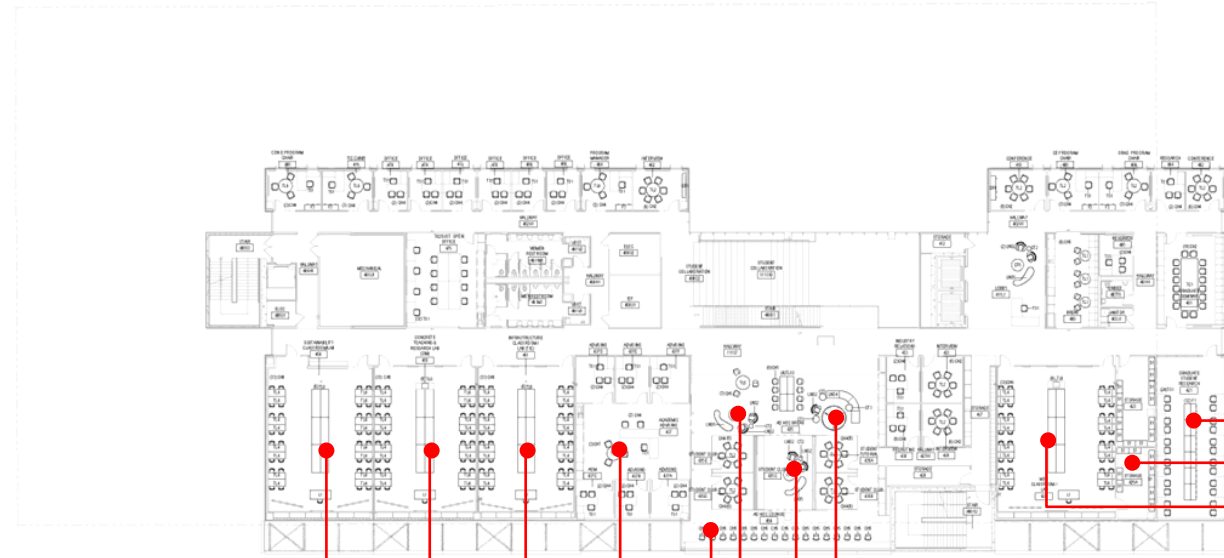

- CH6/TL4/TL8/L1
- CH7/TL6/CH4
- TS1/F1
- S1
- CH6/TL4/TL8/L1
- LNG4/CT3/CT5
- LNG2/CT3/CT6 LNG1/CT1
- CH5



TS1 F1



CH6 TL4/TL8 L1

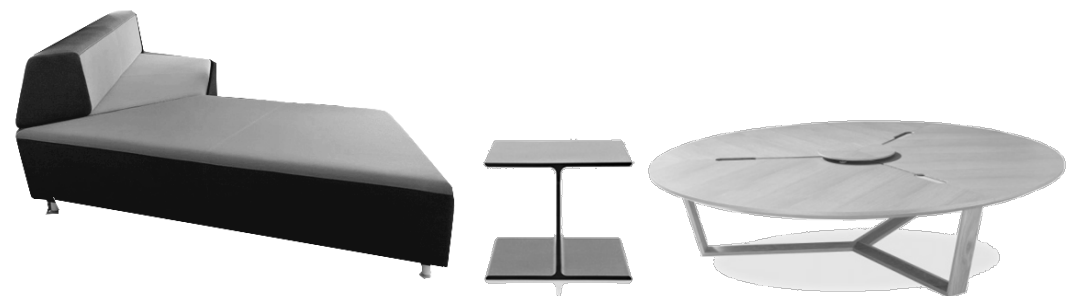

LNG4 CT3 (18") CT5

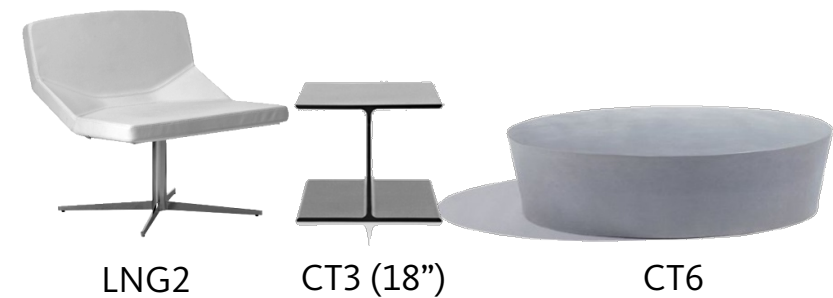

LNG2 CT3 (18")



CT6

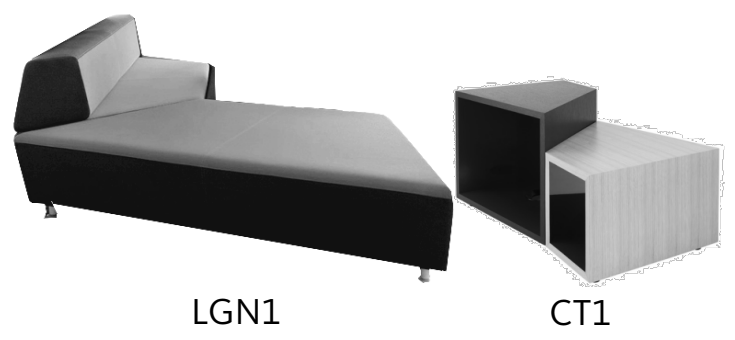

LGN1 CT1



CH5



CH7



TL6



CH4

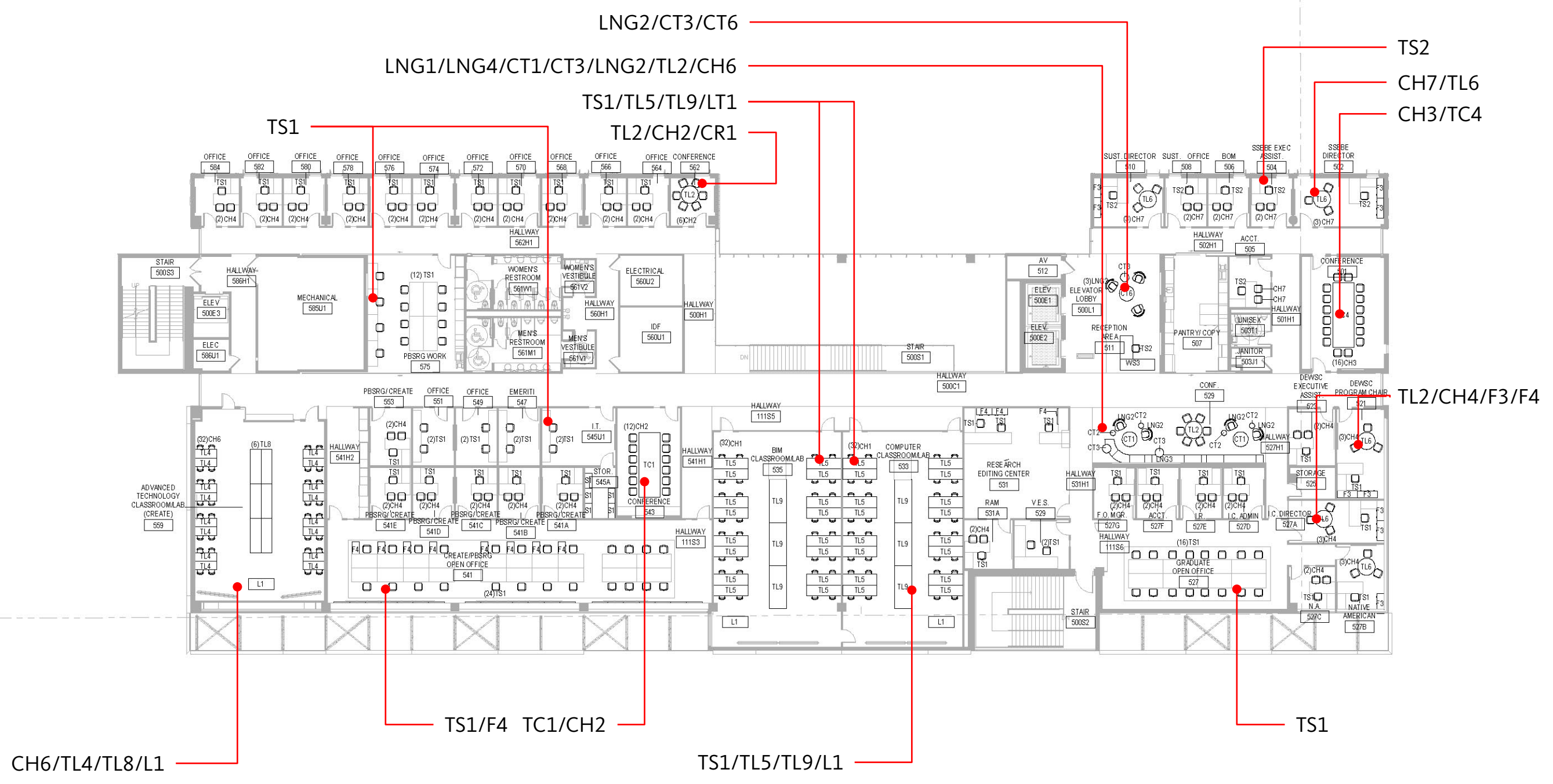

LOOSE ITEM FURNISHING

Level 05

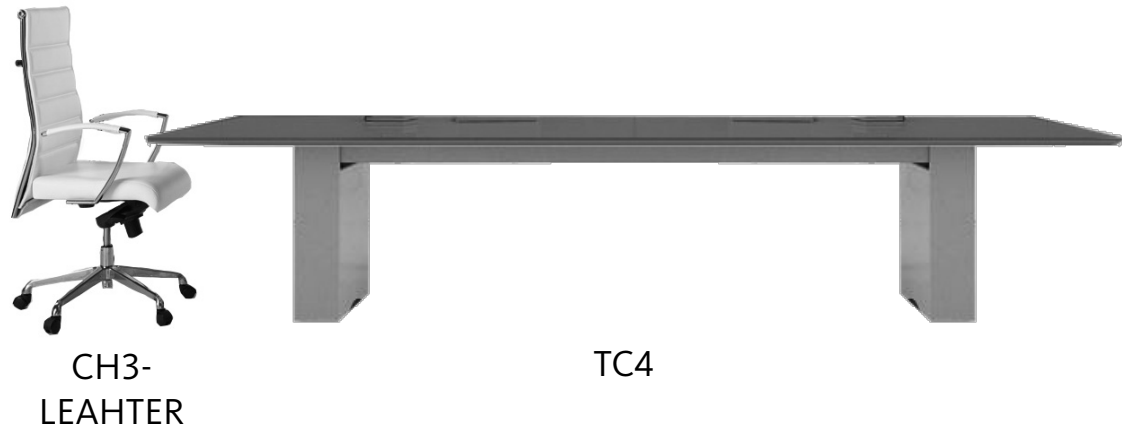
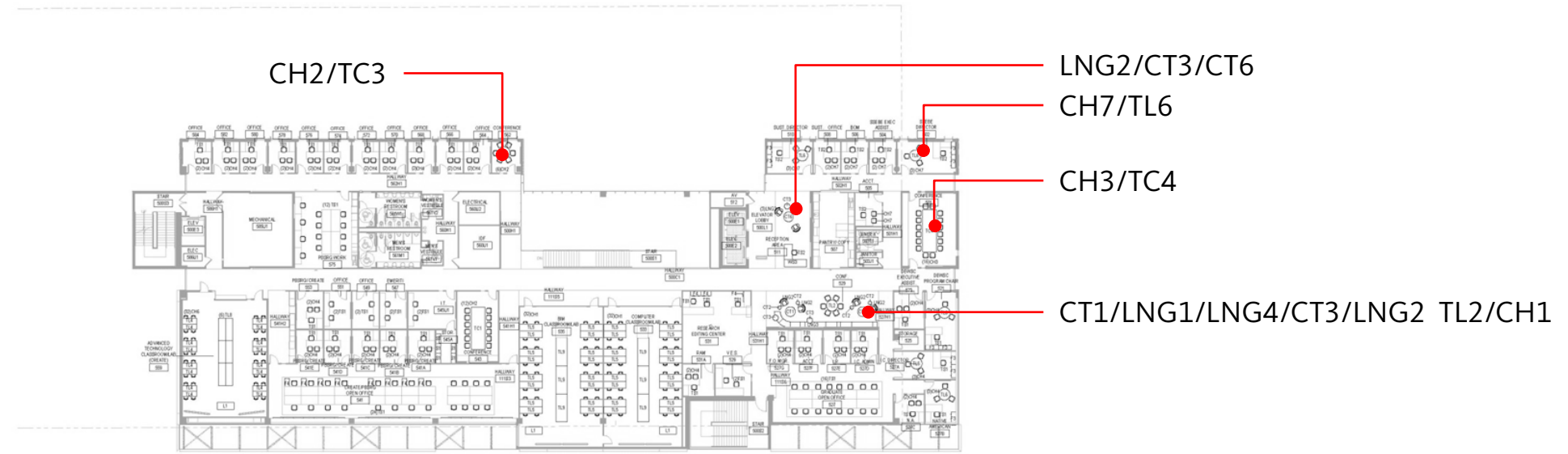

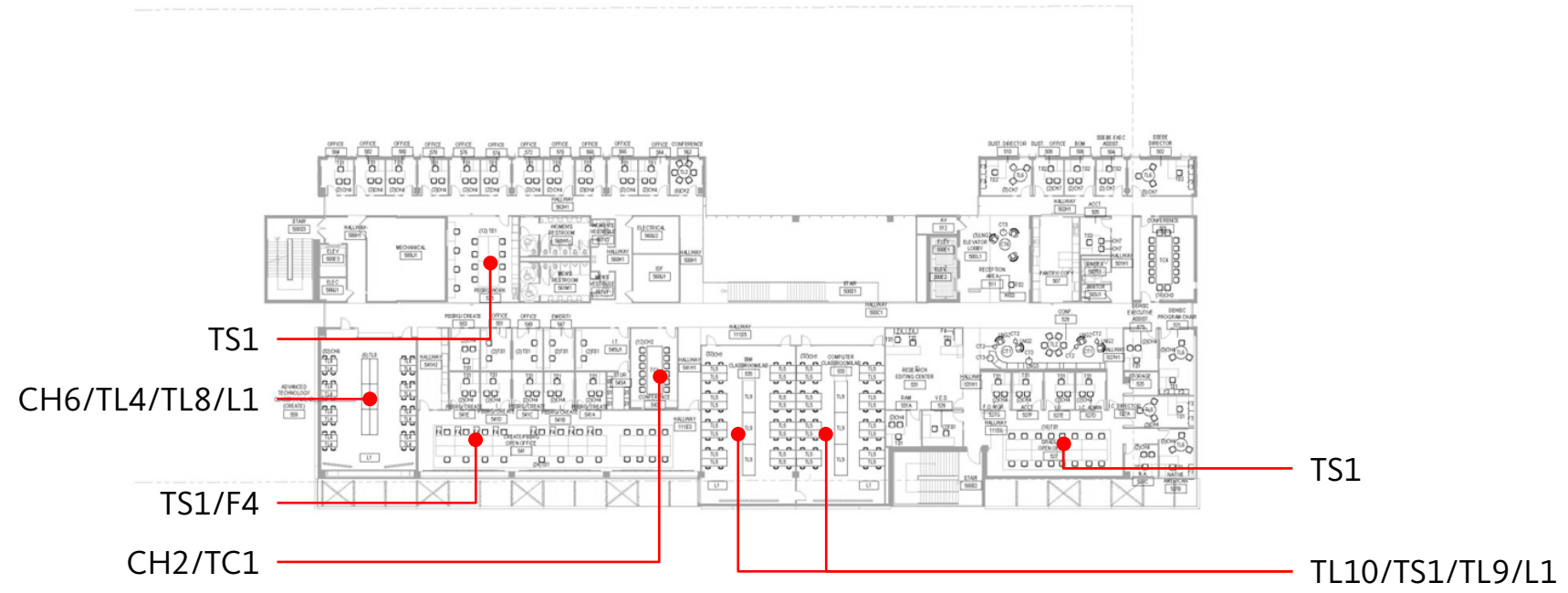

TS1



TL10

CH1



TL9



L1



CH2



TC1



TS1



F4



CH6



TL4/TL8



L1



TS1 – TYPICAL TASK CHAIR
STEELCASE, THINK CHAIR - ADJUSTABLE HEIGHT AND ARMS, MESH BACK, MID-GRADE SEAT FABRIC, 5 STAR BASE



TS2 - EXECUTIVE TASK CHAIR
SOURCE INTERNATIONAL, PURL TASK CHAIR - HIGH BACK, 5 STAR BASE, ARM AND HEIGHT ADJUSTABLE, HIGH GRADE LEATHER SEAT AND BACK



CH1 - TRAINING/CLASSROOM CHAIR
VERSTEEL,QUANTA CHAIR - W/ CASTERS AND ARMS - NONUPHOLSTERED, WOOD FINISH TBD



CH2 - CONFERENCE CHAIR
FIRST OFFICE, SLEEK CONFERENCE CHAIR - 5 STAR BASE, MID BACK, HEIGHT ADJUSTABLE, MID GRADE FABRIC FOR SEAT AND BACK
ALT – SOURCE INTERNATIONAL, MID BACK, PURL

CH3 - EXECUTIVE CONFERENCE CHAIR
FIRST OFFICE, SLEEK CONFERENCE CHAIR - 5 STAR BASE, HIGH BACK, HEIGHT ADJUSTABLE, HIGH-GRADE LEATHER FOR SEAT AND BACK
ALT – SOURCE INTERNATIONAL, PURL MID BACK



CH4 - SIDE CHAIR
ALLERMUIR FLEUR SIDE CHAIR - WOOD ARMS AND BACK, UPHOLSTERED SEAT WITH MID GRADE FABRIC, CHROME METAL LEG



CH5 - BREAK ROOM CHAIR
HIGH TOWER, FOUR CAST LINE CHAIR WITH ARMS - POLYAMIDE SEAT, CHROME METAL FRAME AND LEG, FINISH TBD



CH6 - LAB/CLASSROOM CHAIR
COALESSE, KART NESTING STOOL - HEIGHT ADJUSTABLE W/ ARMS AND CASTERS, NONUPHOLSTERED - FINISHES TBD - COORDINATES WITH TL-4

CH10 - LAB/CLASSROOM CHAIR
COALESSE, KART NESTING STOOL - HEIGHT ADJUSTABLE W/ ARMS AND CASTERS, MID-GRADE UPHOLSTERED SEAT - FINISHES TBD



CH7 - EXECUTIVE SIDE CHAIR
DAVIS GINGKO SIDE CHAIR - VENEER SHELL AND WOOD BASE, WOOD FINISH TBD



CH8 - OUTDOOR CHAIR (ALT. LINE ITEM)
HERMAN MILLER, CHAIR_ONE STACKING BASE - WHITE ALUMINUM SEAT AND LEGS, HIGH GLOSS FINISH



CH9 – OUTDOOR LOUNGE CHAIR (ALT. LINE ITEM)
HERMAN MILLER, MEDICI OUTDOOR LOUNGE - WOOD FINISH; NATURAL THERMO OILED ASH



TL1 – TRAINING TABLE
 VERSTEEL PACES NESTING/TRAINING TABLE
 24" D X 60" L X 28"H FLIP P.LAM TOP/NESTING
 TABLE WITH METAL LEG ON CASTERS.
 STRAGHT EDGE. TABLE LINK AT ENDS WITH
 MODELTY PANEL. WIRE MANGEMENT TRAY.
 CONCEALED WIRE MANAGEMNT LEG.



TL5 – STUDENT COMPUTER TABLE
 (SEAT 2 WITH 2 MONITORS PER EACH STUDENT)
 VERSTEEL PACES NESTING/TRAINING TABLE
 30"D X 96"W X 28"H P.LAM TOP/NESTING TABLE WITH
 METAL LEG ON CASTERS. STRAGHT EDGE. TABLE LINK AT
 ENDS WITH MODELTY PANEL. WIRE MANGEMENT TRAY.
 CONCEALED WIRE MANAGEMNT LEG.



TL2 – ROUND MEETING TABLE (48"D)
 ROUND MEETING TABLE - 48"D - CORIAN TOP -
 FINISHES TBD - (1) DATA PORT @ CONF. 529 ONLY



TL6 - EXECUTIVE ROUND MEETING TABLE (48"D)
 HERMAN MILLER, EAMES ROUND TABLE - WOOD
 VENEER TOP, METAL BASE, FINISHES TBD



TL3 – BREAK ROOM TABLE (36"D)
 WCI , MARK IV - W/ CORIAN TOP, METAL POWDER
 COATED LEG AND BASE



TL7 – OUTDOOR TABLE (36"D)
 WCI, PLATFORM OUTDOOR TABLE - W/ POWDER COATED
 BASE AND TOP



TL4/TL8/TL9
TL4 – STUDENT LAB/TRAINING TABLE
 24"X 60"X34"H, RESIN TOP, PAINTED STAINLESS STEEL
 LEG/BASE ON CASTERS
TL8 – LAB/TRAINING CENTER TABLE
 30"X 96"X 34"H, RESIN TOP, PAINTED STAINLESS STEEL
 LEG/BASE ON CASTERS
TL9 – BIM/COMPUTER CENTER TABLE
 48"X 120"X 28"H, RESIN TOP, PAINTED STAINLESS STEEL
 LEG/BASE ON CASTERS



TL10 – COMPUTER TRAINING TABLE
 COALESSE , TRAIN TABLE - 24"X60" STAIGHT EDGE
 TOP W/ METAL LEG ON CASTERS, WIRE
 MANAGEMENT TRAY, METAL MODESTY PANEL -
 FINISHES TBD



TC1 - CONFERENCE TABLE (5'-0"X15'-0")

DAVIS, TIX DOUBLE CONFERENCE TABLE - (2) I-LEG, (1) CENTER LEG WITH CONCEALED DATA WITH ACCESS ON BOTH SIDES, SOLID WOOD TOP, STAINLESS STEEL LEG WITH CLEAR FINISH - TBD

TC2/TC3

TC-2 - CONFERENCE TABLE (4'-0" X 15'-0") SEAT 14

NUCRAFT FLOW CONFERENCE TABLE - W/ (2) DATA PORTS, CONCEALED-DATA-RECTANGLE LEG, WHITE CORIAN TOP W/ STRAIGHT EDGE

TC-3 - CONFERENCE TABLE (5'-0" X 12'-6") SEAT 12

NUCRAFT, FLOW CONFERENCE TABLE - W/ (2) DATA PORT, CONCEALED-DATA-RECTANGLE LEG, WHITE CORIAN TOP W/ STRAIGHT EDGE

TC4 - EXECUTIVE CONFERENCE TABLE (5'-0" X 15'-0")

NUCRAFT, FLOW XT CONFERENCE TABLE - W/ (2) DATA PORT, CONCEALED-DATA-RECTANGLE LEG, VENEER TOP W/ HARDWOOD STRAIGHT EDGE

TC5 - BIG MEETING TABLE SEAT 4-6 (48X96X28H)

STEELCASE, CAMPFIRE BIG TABLE - SPLIT TOP W/ TROUGH, FINISHES TBD,

TC6 - COUNTER HEIGHT MEETING TABLE 60"X66"X38"H

STEELCASE , MEDIASCAPE CONFERENCE D-SHAPED TABLE - FINISHES TBD



CT1 (A & B) – COFFEE TABLE
STEELCASE, SEBASTOPOL TABLE
VENEER WOOD EXTERIOR, WHITE P.LAM INTERIOR.
(2)B SHAPE CONFIGURATION



CT2 - SIDE TABLE
GEIGER, I-BEAM OCCASSIONAL TABLE - 16"X16"

ALT -18" DIA. HIGHTOWER MARTINI BLACK TOP
OR STEELCASE CAMPFIRE PERSONAL TABLE



CT3 - MEDIUM SIDETABLE
GEIGER I BEAM COFFEE TABLE - 18"X 18" CLEAR FINISH

ALT -24" DIA. HIGHTOWER MARTINI BLACK TOP OR
STEELCASE CAMPFIRE PAPER TABLE

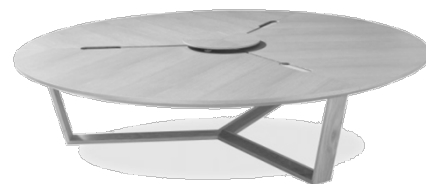

CT5 - LARGE COFFEE TABLE
DAVIS, SITE 2010 ROUND NETWORKING TABLE
W/ POWER & DATA - 84"D, FINISH TBD



CT4 – OUTDOOR COFFEE TABLE (ALT. LINE ITEM)
MAY LIN STONES, 42"X30"X11", OUTDOOR COFFEE TABLE, FINISH TBD

CT6 - OUTDOOR COFFEE TABLE (USED INDOOR)
MAY LIN STONES, 42"X30"X11", OUTDOOR COFFEE TABLE, FINISH TBD

ALT- COALESSE TREE TABLE



CT7 - OUTDOOR SIDE TABLE (ALT. LINE ITEM)
DWR, FRANK GEHRY LEFT TWIST CUBE - FINISH TBD - 18"SQU.



LNG1/LNG4/LNG5 - LOUNGE BENCH GROUPPINGS
 STEELCASE MEDIASCAPE LOUNGE
 ALL UPHOLSTERED, HIGH GRADE UPHOLSTERED FABRIC
 SEE FUNITURE PLAN FOR SHAPE CONFIGULATION AND
 SIZE, SEE SPEC FOR DETAIL



LNG2 - LOUNGE CHAIR
 GORDON INTERNATIONAL, FORMULA SWIVELING
 PEDESTAL BASE LOUNGE CHAIR, HIGH-GRADE FABRIC,
 STAINLESS STEEL LEG/BASE - FINISHES TBD



CR1 - CREDENZA
 NUCRAFT, PERFORMANCE CREDENZA - 72"X25"X29"
 CONFERENCE HEIGHT - STRAIGHT EDGE, 3 DRAWER
 - PULL OUT RECYCLE/TRASH BINS, SLIDING
 EQUIPMENT RACK - VENEER WOOD WITH SILVER
 FINISH HARDWARE, FINISHES TBD



L1 - LECTURN/INSTRUCTOR DESK
 24"X72", STEELCASE, VERB INSTRUCTOR STATION -
 W/ CADDY AND MODESTY PANEL - CORIAN TOP,
 FINISHES TBD



L2 - AUDITORIUM LECTURN
 NUCRAFT, HIGH-TECH LECTURN - FULLY INTEGRATED
 A/V, SLIDE OUT SHELF, FIXED UPPER SHELF W/ PULL
 OUT DRAWER, GOOSENECK MICROPHONE, LIGHT W/
 DIMMER, CABLER SHROUD ON CASTERS - WOOD
 FINISHES TBD



F1 - OPEN OFFICE FILE
 KNOLL, REFF - 2H - PAINTED FINISH TBD - TO FIT UNDER
 WORKSURFACE WHERE APPLICABLE



F-3 PRIVATE OFFICE FILE
 KNOLL, REFF - 2H - 48"L W/ WOOD TOP, FINISH TBD - TO
 FIT UNDER WORKSURFACE WHERE APPLICABLE;
 PROVIDE SINGLE WOOD PANEL TOP FOR MULTIPLE
 STAND ALONE UNITS

F-4 - PRIVATE OFFICE FILE
 COALESSE, TOPO FREESTANDING PEDESTAL - 2H - 36"L,
 PAINTED FINISH TBD - TO FIT UNDER WORKSURFACE
 WHERE APPLICABLE - COORDINATES W/ WS-7

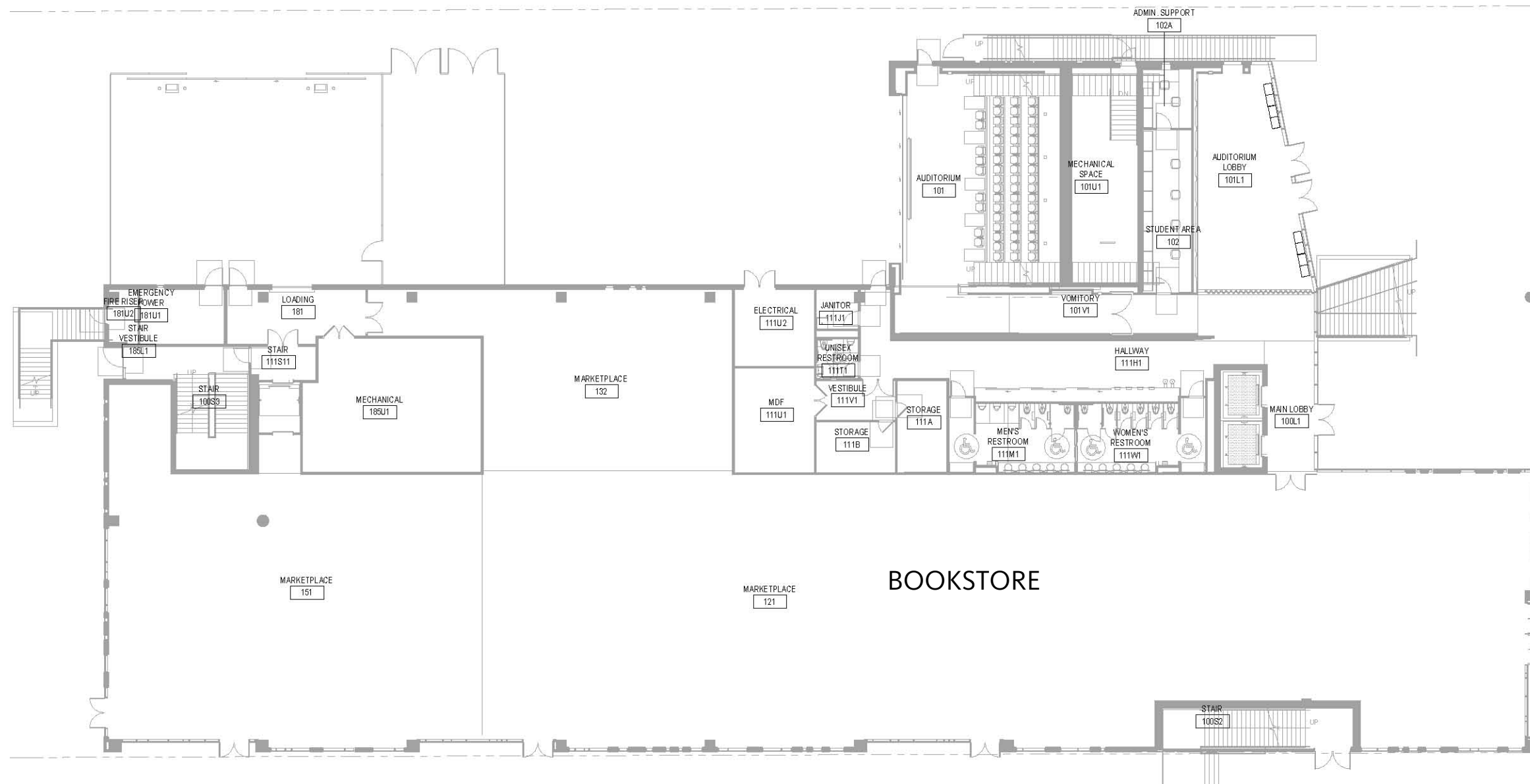

BOOKSTORE

NO SYSTEMS FURNITURE

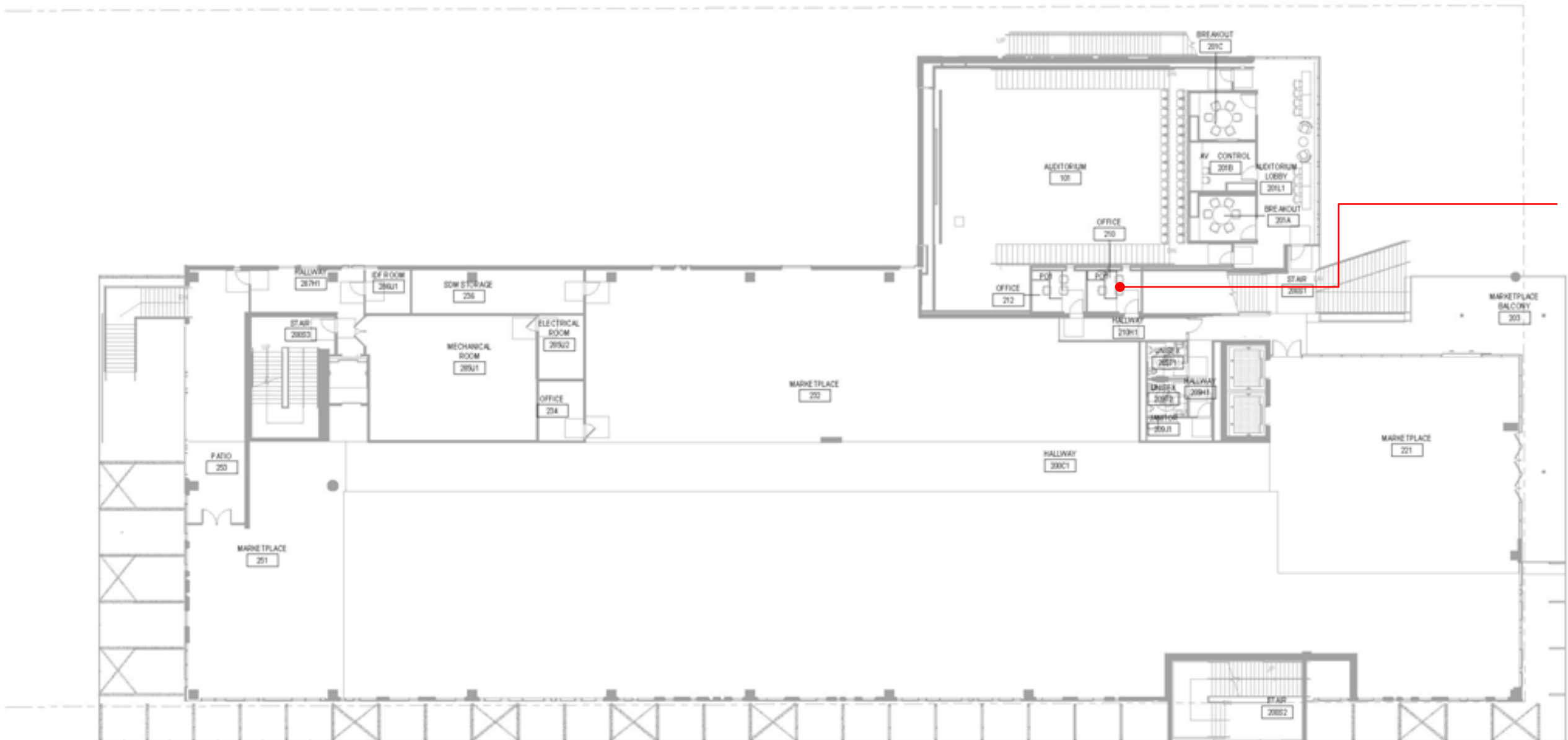

PO1

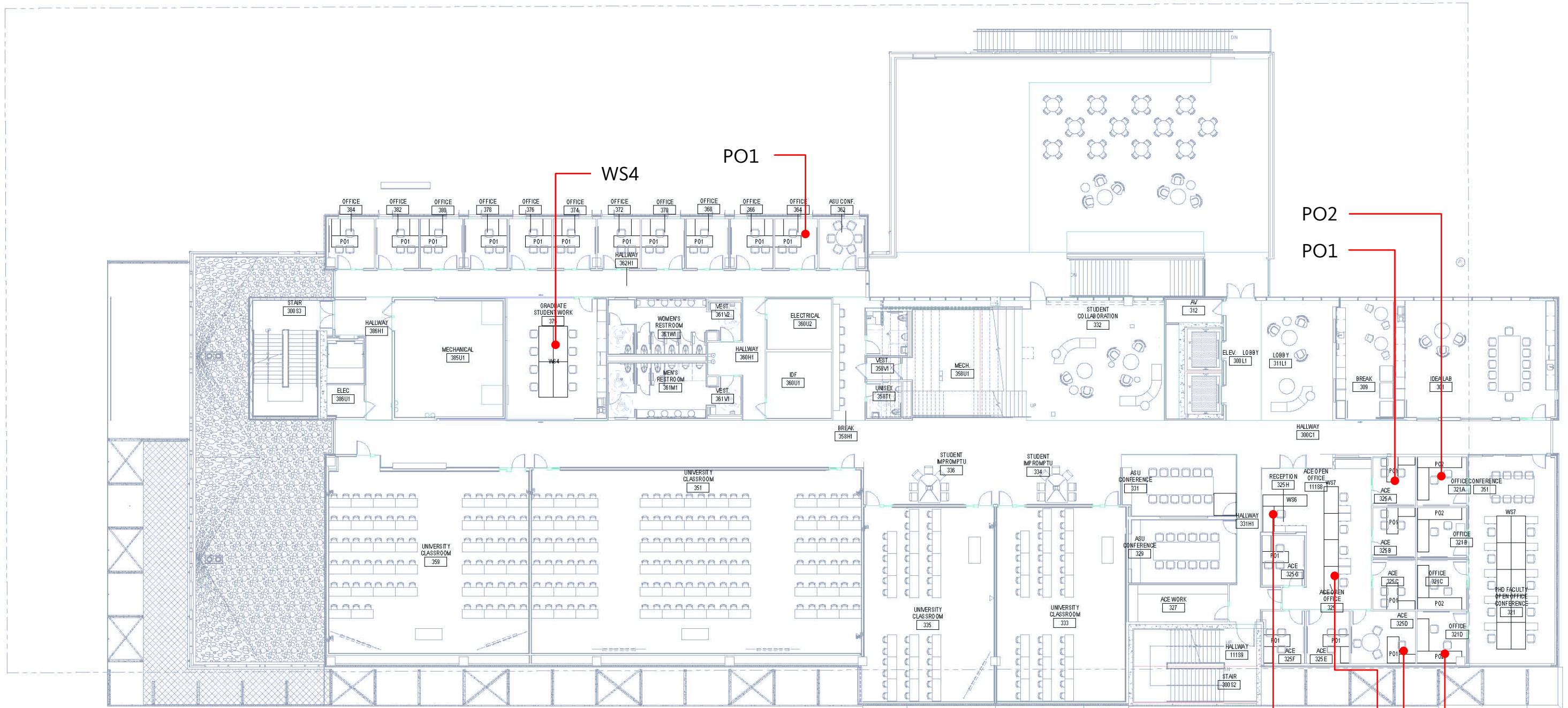

PO2
PO1

WS4

PO1

WS6
WS7
PO1
PO2

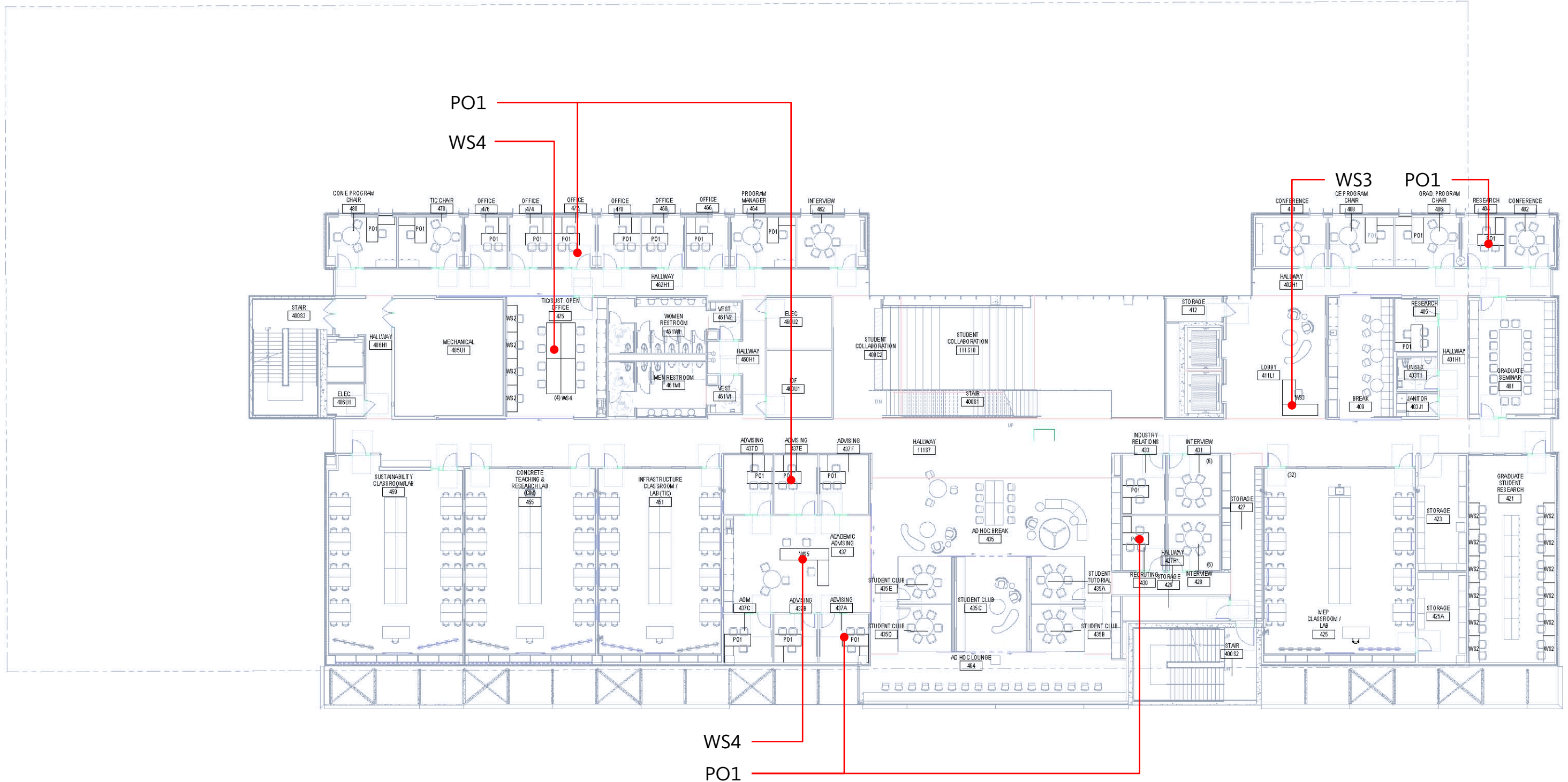

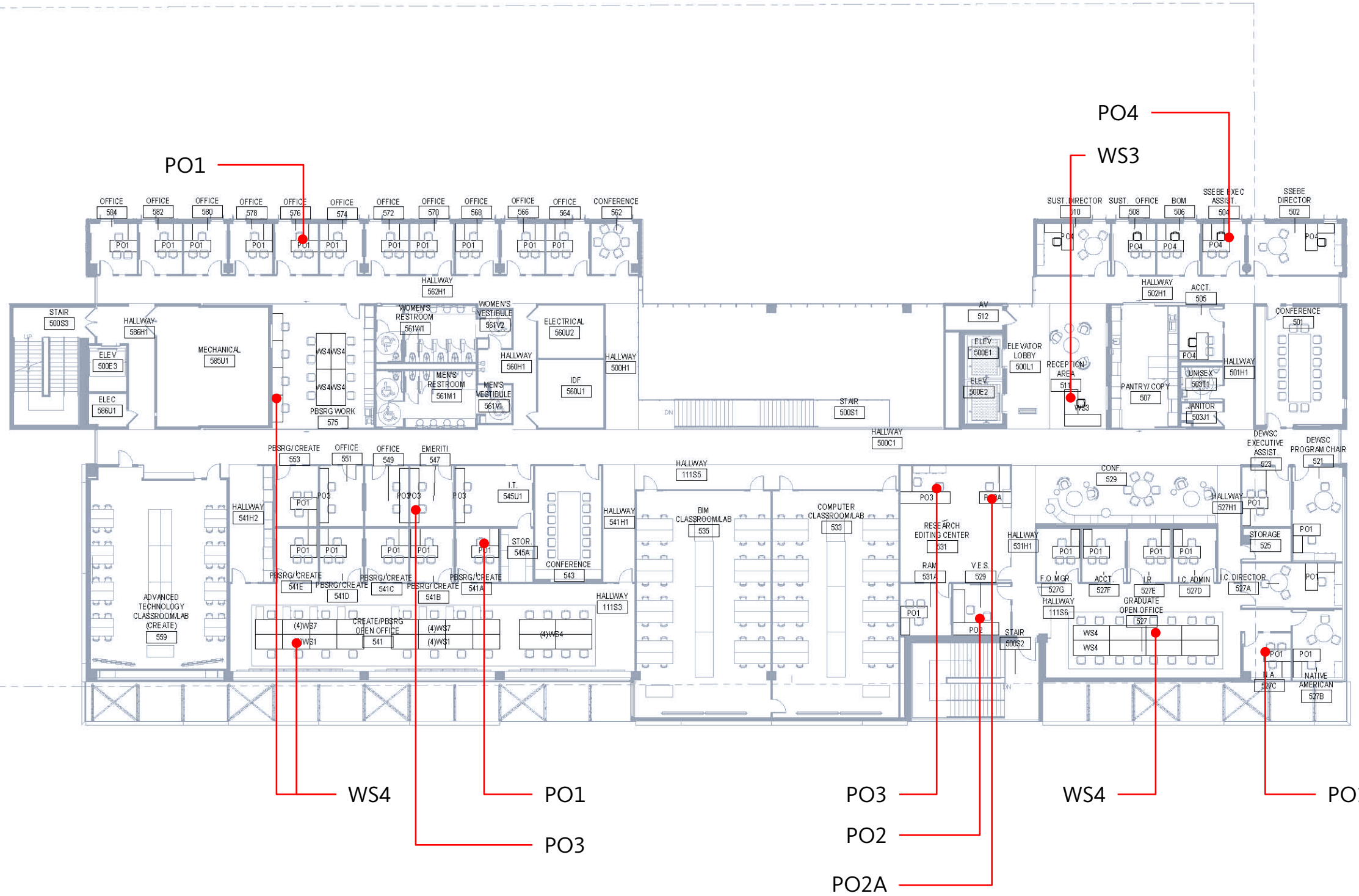

WORKSTATION - WS

DESIGN ESTHETIC SHOWN HERE IS OF KNOLL, ANTENNA SYSTEMS.

PROVIDE CONCEALED WIRE MANAGEMENT TRAY FOR ALL SYSTEMS.



WS1/WS2/WS4/WS7 WORKSTATION BENCHING SYSTEM

WS1 – 6' X 36"D BENCHING SYSTEM
28"H, C-LEG, 36"D WORKSURFACE, PL.AM TOP, B/B/F METAL PED WITH PENCIL TRAY.

WS2 – 6' X 30"D BENCHING SYSTEM
28"H C-LEG, WORKSURFACE, PL.AM TOP, B/B/F METAL PED WITH PENCIL TRAY. MID GRADE FABRIC TACKABLE PANEL.

WS4 – LARGE SHARED 8' X 36"D BENCHING SYSTEM
(DOUBLE SIDED BIG TABLE) WITH HINGED ACCESS TOP AND HIGH GRADE FABRIC SCREEN, 2 WORKER SHARED, 36"D WORKSURFACE WITH P.LAM TOP, B/B/F METAL PED WITH PENCIL TRAY.

WS7 – 6'X 36"D BENCHING SYSTEM
28"H C-LEG, PL.AM TOP, B/B/F METAL PED WITH PENCIL TRAY. MID GRADE FABRIC TACKABLE PANEL. COORDINATE WITH F4.



WS3/WS5/WS6 WORKSTATION - RECEPTION

WS3 – 8X8 RECEPTION STATION
30"D WORKSURFACE, P.LAM . TOP WITH WOOD EDGE (AS SHOWN IN THE IMAGE). WOOD TRANSACTION FRONT AND TOP. TOP, B/B/F WOOD PED WITH PENCIL TRAY

WS5 – 6'-6" X 11'-0" RECEPTION STATION
WITH RETURN. 30"D WORKSURFACE, P.LAM . TOP WITH WOOD EDGE (AS SHOWN IN THE IMAGE). WOOD TRANSACTION FRONT AND TOP. TOP, B/B/F WOOD PED WITH PENCIL TRAY

WS6 – 9X9 RECEPTION STATION
WITH RETURN AND 3H (F1) STORAGE BEHIND, P.LAM .TOP WITH WOOD EDGE (AS SHOWN IN THE IMAGE). 30"D WORKSURFACE. WOOD TRANSACTION FRONT AND TOP. TOP, B/B/F WOOD PED WITH PENCIL TRAY

PRIVATE OFFICE - PO

DESIGN ESTHETIC SHOWN HERE IS OF KNOLL, ANTENNA SYSTEMS.

PROVIDE CONCEALED WIRE MANAGEMENT TRAY FOR ALL SYSTEMS.



PO1/PO2 PRIVATE OFFICE

PO1- 6'X6' SMALL PRIVATE OFFICE

P.LAM FINISH, L-SHAPE WITH OVERHEAD STORAGE AND TACKABLE PANEL WITH MID GRADE FABRIC. B/B/F METAL PED WITH PENCIL TRAY. 2H METAL LATERAL FILE.

PO2- 10X10 SHARED PRIVATE OFFICE

PLAM FINISHES L-SHAPE W/ OVERHEAD STORAGE & TACKABLE PANEL W/ MID-GRADE FABRIC, (2) B/B/F METAL PED W/ PENCIL TRAY

PO2A- 7X8 SHARED PRIVATE OFFICE

P.LAM FINISH, L-SHAPE WITH OVERHEAD STORAGE AND TACKABLE PANEL WITH MID GRADE FABRIC. B/B/F METAL PED WITH PENCIL TRAY.

PO3 SHARED PRIVATE OFFICE

PO3 - 8'X 30"D SHARED PRIVATE OFFICE - BENCH

OVERHEAD STORAGE & TACKABLE PANEL W/ MID-GRADE FABRIC. (2) B/B/F METAL PED W/ PENCIL TRAY

PO4 EXECUTIVE PRIVATE OFFICE

PO4- EXECUTIVE PRIVATE OFFICE

WOOD FINISH, L-SHAPE WITH OVERHEAD STORAGE, WOOD FINISH CREDENZA, AND TACKABLE PANEL WITH HIGH GRADE FABRIC. B/B/F METAL PED WITH PENCIL TRAY. (1) 2H WOOD FINISH LATERAL FILE.