



Environmental Health and Safety

Compressed Gas Safety Program

Revised April 2021

480-965-1823  
[asuehs@asu.edu](mailto:asuehs@asu.edu)

# Table of Contents

1. Introduction and purpose
2. Scope and application
3. Responsibilities
4. Training requirements and competency assessment
5. Personal Protective Equipment
6. Labeling requirements
7. Proper storage of compressed gas cylinders
8. Securing compressed gases cylinders
9. Proper handling and use of compressed gas cylinders
10. Cylinder size
11. Regulators
12. Valves on compressed gas cylinders
13. Restrictive Flow Orifices (RFOs)
14. Specific requirements of compressed gas cylinders
15. Types of compressed Gases
16. Flammable, toxic, highly toxic and pyrophoric compressed gases
17. Oxidizers
18. Flammables
19. Compressed gas cylinder emergencies
20. Appendix A – Definitions
21. Appendix B – General Guidelines for Flammable Gases

22. [Hydrogen](#)
23. [Guidelines for hydrogen use and storage](#)
24. [Appendix C – Dewar Safety](#)
25. [Appendix D – Gas Monitoring and Detection](#)
26. [Appendix E – Specialty Gas Use and Handling Requirements](#)
27. [Appendix F – Gas Cabinets](#)
28. [Figure 1: Gas Cabinet Specification with Minimum Purge Capability](#)
29. [Figure 2: Gas Cabinet with Control Panel Specification](#)
30. [Gas Cabinet Worksheet](#)

## Introduction and purpose

Arizona State University continually strives to provide a learning, teaching, and research environment free from recognized hazards. The University requires the safe handling, use, and storage of compressed gas cylinders to protect employees and students from potential physical and health hazards associated with using compressed gases in laboratories or other locations that are part of the University.

## Scope and application

Arizona State University wants to ensure employees who handle compressed gases understand the health and physical hazards of the compressed gas cylinders, the contents, proper handling, use, storage, and emergency procedures. To accomplish this, the Environmental Health and Safety Department, or EHS, will ensure compliance to the Occupational Safety and Health Administration, OSHA, Compressed Gases in 29 CFR, Subpart H - Hazardous Materials 1910.101 to 1910.105, 110, 111, and the Compressed Gas Association, CGA, requirements.

Compressed gas cylinders can present a variety of hazards due to their pressure and/or contents. This program covers requirements that must be followed for the use of all compressed gases. In addition to the standard required work practices for inert gases, flammable and toxic gases as defined in [EHS 122 Compressed Gas](#) requires the installation and maintenance of gas cabinets approved by the ASU Campus Fire Marshal. Additional controls and work practices including, but not limited to, gas monitors, emergency shutoffs, proper equipment design, leak testing procedures, and the use of air supplying respirators for certain toxic, and highly toxic gases may be required.

This program applies to the storage, use, and handling of gases in pressurized portable containers and gas systems. The primary focus of this program is on single gas uses and systems. Additional requirements may be applied to:

- Large, compressed gas facilities, storage areas, or use areas
- Use of multiple gases in a single control area or building.

All permanent installations of compressed gases must follow the CPMG permitting process and all [toxic, highly toxic and flammable compressed gas](#) cylinders must include the installation and maintenance of a gas cabinet approved by the ASU Fire Marshal (with the Fire Safety and Prevention division of EHS). All use of portable flammable compressed gas systems must be approved either through the CPMG permitting process or through the use of the [Prior Approval Form](#) identified in the ASU Chemical Hygiene Plan. Approved uses of flammable compressed gases will be identified at the point of use by EHS or CPMG in evaluating regulatory compliance during inspections. Point-of-use identification will include approved gases and concentrations, quantity, and date of approval.

The ASU Campus Fire Marshal's Office will review permit requests for consistency with all applicable codes, standards and local adopted specifications, including but not limited to the following codes. Any non-conformance to these codes requirements must be justified and approved by the ASU Campus Fire Marshal's Office as the "authority having jurisdiction" – AHJ.

- International Fire Code 2018 Edition.
- National Fire Protection Association (NFPA) 101 - Life Safety Code.

- National Fire Protection Association (NFPA) 13 - Standard for the Installation of Sprinkler Systems.
- National Fire Protection Association (NFPA) 2 - Hydrogen Technologies Code.
- National Fire Protection Association (NFPA) 45 - Fire Protection for Laboratories Using Chemicals.
- National Fire Protection Association (NFPA) 55 - Compressed Gases and Cryogenic Fluids Code.
- National Fire Protection Association (NFPA) 72 - National Fire Alarm and Signaling Code.

## **Responsibilities**

### **Academic Unit Leadership**

Academic Unit Leadership are responsible for establishing and implementing department information and training programs for their respective areas. Delegation of this responsibility to the Principal Investigator, or PI, laboratory supervisor or manager, Compliance Officer, and/or safety committee is acceptable. It is the responsibility of the Unit Leadership, Dean, Director, Chair or designee to:

- Understand the processes and hazards in the work area.
- Ensure that University policies are enforced, and safe work practices are followed; and
- To provide for and acquire adequate instruction in the use and maintenance of compressed gas cylinders for employees.

### **Environmental Health and Safety – EHS**

- Ensures that University policies are enforced, and safe work practices are used.
- Provides gas system planning guidance related to new construction and renovation.
- Assists, advises, and provides training as necessary.
- Reviews and approves procedures for all controlled, toxic, highly toxic, flammable, pyrophoric or hazardous gases.
- Assists, advises, and instructs University employees in the care and handling of compressed gas cylinders and gas systems.

### **Compliance Officers**

Arizona State University's Environmental Health and Safety Management Policy (EHS MP) calls for the University to be a model of quality in environmental health and safety. Compliance Officers are critical links in the development of this level of quality. Compliance Officers undergo special training and can be a crucial step in maintaining compliance to EHS programs. They:

- Assist and review compressed gas storage and installation to ensure safe work practices are used.
- Coordinate activities between compressed gas uses and the EHS department.

## ASU employees

- Obtain required training to safely work in the laboratory area.
- Perform all work with compressed gases in accordance with ASU policies and prudent safe work practices.

### Training requirements and competency assessment

Each ASU employee (including faculty, staff, researchers, and part-time employees) who physically transports and makes connections to compressed gas systems for use at ASU must complete compressed gas safety training approved by EHS. Lab specific training is considered adequate for connecting tubing and adjusting flows at valves for pressures less than 30 psig except for highly toxic and pyrophoric gases. EHS provides a web-based training program referred to as [EHS Compressed Gas Safety - under pressure](#) that includes a mentorship component that requires each participant to demonstrate competency in the handling and use of compressed gases.

ASU faculty members sponsoring graduate students, visiting researchers, or other personnel not identified above as qualified licensed contractors will follow this policy. Other training programs may be acceptable and credit can be given by EHS for other training programs after verifying equivalency. Please contact the EHS office for more information at [asuehs@asu.edu](mailto:asuehs@asu.edu).

The training program mentorship will be provided by the PI, a Lab Manager, or EHS and will include operational training on specific compressed gas cylinder hazards on campus.

Employees will require refresher training under any of the following conditions:

- Changes in the types of cylinder systems or equipment used that would render previous training obsolete.
- Changes in the workplace rendering previous training obsolete.
- Observation of unsafe work practices and/or violations of safety rules involving the use of compressed gas cylinders or equipment, or observed behavior indicating that the employee has not retained the required training.

### Personal protective equipment

- Face protection: A face shield shall be worn when there are additional hazards to the face.
- Foot Protection: Use closed toed shoes when moving or transporting cylinders for occasional movement of cylinders. Safety toed shoes should be used for frequent movement of compressed gas cylinders.
- Gloves and Clothing: To protect against frostbite, corrosives, and pinch points.
- Safety Glasses or Goggles: Use especially when connecting and disconnecting gas regulators and lines.

### Labeling requirements

Compressed gas cylinders shall be legibly marked for the purpose of identifying the gas content with either the chemical or the trade name of the gas. Such marking shall be by means of stenciling, stamping, or labeling, and shall not be readily removable. Whenever practical, the marking shall be located on the shoulder of the cylinder – OSHA Standard 29 CFR 1910.253 (b) (1) (ii).

- A durable label should be provided that cannot be removed from the compressed gas cylinder.
- Color-coding is not a reliable means of identification; cylinder colors vary from supplier to supplier, and labels on caps have no identification value because many caps are interchangeable.
- Compressed gas cylinders that do not clearly identify its contents by name should not be accepted for use.
- If the labeling on the gas cylinder becomes unclear or defaced so that the contents cannot be identified, the cylinder should be marked “contents unknown” and the manufacturer must be contacted regarding appropriate procedures for removal.
- Tags should be attached to the gas cylinders on which the names of the users and dates of use can be entered.

### Proper storage of compressed gas cylinders

All compressed gas cylinders must be properly stored in compliance with OSHA, IFC and NFPA code requirements. Cylinders internal pressure can reach over 2,000 psi. In the event of a container breach, the cylinder becomes a projectile hazard.

Signage required at compressed gas cylinder storage locations may include any of the following. Specific requirements will be identified by the ASU Campus Fire Marshal’s Office.

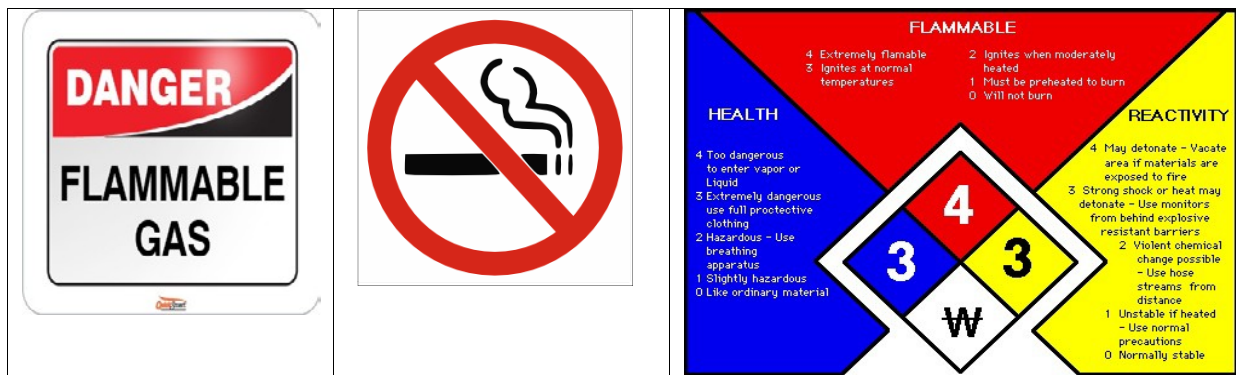

The following precautions should be taken for the storage of compressed gas cylinders:

1. Cylinders must be stored in a dry, cool, well-ventilated, secure area.
2. All cylinders whether empty or full must be stored upright and secured by chains, straps or in racks to prevent them from falling.
3. Segregated cylinders by contents. For example, flammable gases must be stored separately from oxidizing gases by a distance of 20 feet or a 5-foot high, one-hour fire-rated wall.
4. Prevent smoking or open flames in oxidizer or flammable gas storage areas.
5. Do not expose cylinders to corrosive materials such as corrosive gas or other combustible materials.
6. Segregate full and empty cylinders, use “first in first out” inventory control method.

7. Store cylinders away from heavily traveled areas and emergency exits.
8. Provide adequate access for cylinder handling and material handling carts.
9. Visually inspect stored cylinders on a routine basis, look for indication of leakage or problems.
10. All cylinder storage areas, outside or inside, shall be protected from extreme heat and cold and from access by unauthorized personnel. Prevent indoor or outdoor temperatures from exceeding 125 °F or 52 °C.



## Securing compressed gases cylinders

Cylinders must be secured in one or more of the following ways:

- At a minimum, cylinders must be secured at approximately 2/3 the height of the cylinder – secured above the midpoint, but below the shoulder. When cylinders are secured by a chain or strap, the preferable method is to secure them in two locations – one strap or chain 2/3 the height of the cylinder and another strap or chain 1/3 up from the bottom of the cylinder.



- By a noncombustible rack, framework, cabinet, approved strapping device, secured cylinder cart, or other substantial assembly that prevents the cylinder from falling. Cylinder carts are for temporary use only.
- By a noncombustible, two-point restraint system (e.g., chains) that secures the cylinder. Nesting of cylinder is **not** an approved method to secure cylinders. Individual cylinders can use a bracket or saddle to support the cylinder.



- Compressed gas cylinders must be protected from sources of heat while stored in a well-protected, well-ventilated, and dry location away from highly combustible materials.
- Gas cylinders must be secured to prevent falling due to accidental contact or vibration.



# Methods of securing cylinders

## Recommended

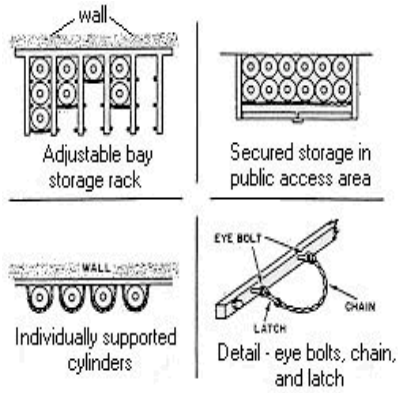

## Not recommended

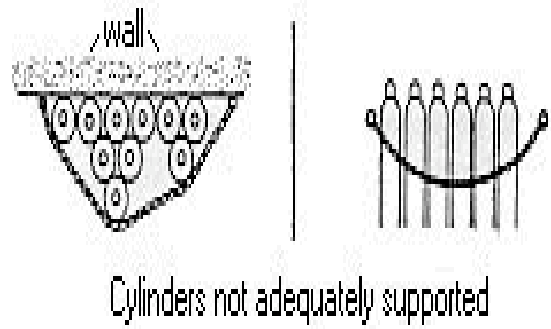

## Recommended

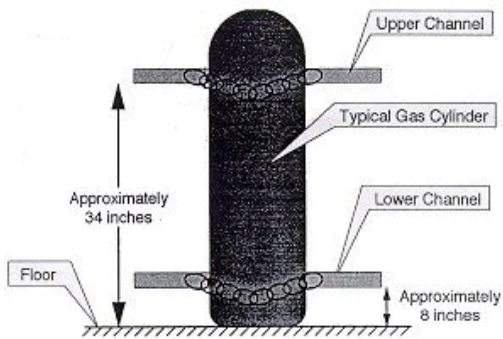

## Not recommended

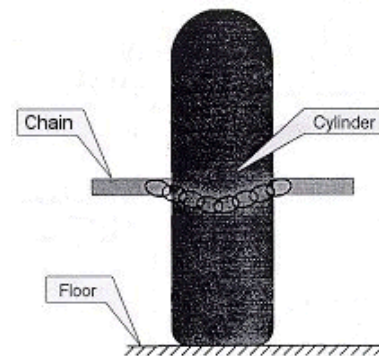

## **Proper handling of compressed gas cylinders**

Compressed gas cylinders should be handled only by those familiar with the hazards and who can demonstrate safety precautions working with cylinders. Cylinders are heavy and awkward to move and improper handling can result in sprain, strain, falls, bruised, or broken bones. Other hazards such as fire, explosion, chemical burns, poison, and cold burns could occur due to mishandling. Eye protection and substantial footwear should always be used when transporting compressed gas cylinders. Always push cylinder carts, never pull.

The following precautions must be taken when handling compressed gas cylinders:

- Avoid dropping the cylinder; do not tamper with pressure-relief devices or remove any product label or shipping hazard labels.
- Compressed gas cylinders must be transported with protective caps in place. Do not lift the cylinder by the protective cap.
- Cylinders must always be transported on wheeled cylinder carts with retaining straps or chains.
- Do not allow grease or oil to come in contact with oxygen cylinder valves, regulators, gauges or fittings; an explosion or fire can result. Oxygen cylinders and apparatus must be handled with clean hands and tools.
- Do not attempt to refill compressed gas cylinders; this is only to be done by qualified manufacturer of compressed gases.
- Do not roll or drag a cylinder over a few feet necessary to position the cylinder.
- Don't try to catch a falling cylinder.
- Open cylinder valve slowly, directed away from your face.
- Wear the appropriate personal protective equipment when handling cylinders.

## **Proper use of compressed gas cylinders**

Take the following precautions to prevent injuries caused by the improper use of compressed gases:

- Close the cylinder valve and release all pressure from the downstream equipment. Disconnect the cylinder anytime there an extended non-use period is expected. Cap the cylinder when not in use.
- Do not discharge the contents from any gas cylinder directly towards any person.
- Do not force cylinder valves connections that do not fit.
- Do not mix gases in a cylinder.
- Do not permit cylinders to become part of an electrical circuit.
- Follow storage and handling requirements.
- Know and understand the gases associated with the equipment being used.
- Never strike an arc on a cylinder. Never introduce another product into the cylinder.
- Never use a compressed gas in any confined space.
- Never use compressed gas to dust off clothing. This could cause injury to the eyes or body and create a fire hazard. Clothing can become chemically saturated and burst into flames if touched by an ignition source such as a spark or cigarette.
- Never work alone when using compressed gas.
- Open cylinder valve slowly and carefully after the cylinder has been connected to the process. Use check valves to prevent reverse flow into the cylinder.
- Prevent sparks and flames from contacting cylinders.







- Use non-sparking tools (brass) when working with flammable/explosive materials.
- Use regulators approved for the specific gas.

If the cylinder's valve does not operate properly, do not attempt to force the valve to turn. The cylinder should be returned to the vendor or ASU Gas Services. Employees must not attempt to repair cylinders or cylinder valves or to force stuck or frozen cylinder valves.

### Cylinder size

Use a returnable cylinders including for lecture bottles or small sizes gas cylinders when hazardous gas sources are needed in small volumes

While the initial purchase cost per cubic foot may be lower when hazardous gases are purchased in full sized cylinders the overall cost of experimental setup which may require local ventilation, gas cabinets, stainless steel piping and purging systems may offset the apparent saving from buying hazardous gases in full sized cylinders

High Pressure Cylinders							
							
Size	R	RR	Q	LD	S	K	T
Height (In)	14	17	32	43	47	51	55
Weight (Lbs)	11	24	46	58	61	113	139
Nominal Volume (CU FT)	20	40	80	122	150	244	330
							N/A

### Tubing and piping connections

Hazardous gases must be dispensed using systems that are properly cleaned and compatible with the gas in use. "Burst pressure" of tubing and piping must be twice the maximum pressure on the second stage regulator. Exceptions as reviewed and approved by ASU FMO and EHS may be made for short sections of tubing when it and the compressed gas cylinder are completely enclosed in a fume hood and low pressures and flow rates are used.

- Always clamp flexible tubing connections. Use a clamp approved for the maximum allowable pressure that the connection is subject to. Never use wire, which may cut the flexible tubing.
- Always leak-check tubing or piping connections when using hazardous gases. Leak check procedures are to be identified in lab specific SOPs.
- Appropriately rated flexible lines are suitable for manifold/cylinder connections.
- Highly Toxic, pyrophoric and flammable gasses shall be piped using orbital weld stainless steel tubing except as follows:
  - All tubing is contained within an exhausted enclosure such as a fume hood or double walled piping.
  - As exempted by the ASU Fire Marshal's Office.
  - exempted in the ASU Chemical Hygiene Plan such as for hydrogen generators.
  - Such tubing shall be installed below ceilings with appropriate gas sensors. I.e. specific to the

specialty gas, connected to an automatic shut-down system for such gas flow if required under permit review.

- Most flexible tubing deteriorates with age or exposure to chemicals or UV light. Replace old flexible tubing before it deteriorates.
- Secure and support tubing or piping to keep it in place and to prevent "whipping" if a connection fails under pressure.
- Shut-off valves at both ends of the gas tubing using gas shutoff valves specific for the gas type and capable of handling estimated maximum gas pressure of such gas cylinder should be considered.
- Teflon tape should never be used on cylinder connections or tube-fitting connections. Use Teflon tape only on pipe threads where the seal is made at the threads. All other connections have metal to metal face seals or gasket seals.
- Use "hard" compatible piping (such as copper and stainless steel tubing) whenever possible (as opposed to flexible or plastic tubing). Never use cast iron pipe or fittings.
- When flexible tubing must be used, select tubing compatible with the chemical and pressure properties of the gas being used in the system. Do not use flexible tubing for toxic, highly toxic or pyrophoric gases. Flexible tubing should only be used within "line of sight." Do not run flexible tubing through walls, ceiling spaces, doorways, or other non-visible pathways if chafing is likely to occur.

## **Regulators**

Use regulators meeting the requirements of UL 252 where applicable. Regulators reduce high pressure gas on a cylinder or process line to a lower usable level. Regulators provide additional safety measures by preventing fire/explosions, chemical or cold burns, poisoning and system over-pressurization. Regulators must be appropriate for the pressure range of the work being performed and ideally should have a pressure rating twice as high as the operating pressure.

Safety considerations include materials of construction to ensure chemical compatibility, and never use any regulator for gases other than those for which it is intended.

Care must be taken when using left-handed threaded connectors. Do not force connected or over tighten a connection. Check the bolt for hash marks indicating a left-handed threaded connection.

Use only regulators with the appropriate CGA connection and

## **Valves on compressed gas cylinders**

Most compressed gas cylinders require the installation of at least one valve. This valve allows the cylinder to contain gases and allows gas to be filled into or emptied from the cylinder.

The cylinder valve is the most vulnerable part of the compressed gas cylinder. Leaks can also occur at the regulator, cylinder stem and at the hose connection.

## Types of valves

Check valves are mechanical valves that permit gases and liquids to flow in only one direction, preventing process flow from reversing. Common types of valves include check, ball, disk, butterfly, gate, diaphragm, needle, and solenoid. Valves can be made of plastic, stainless steel or other material. Valves serve unique requirements so it is important to select the specific type of valve for your operation.

Precautions to consider while using valves are:

- Inspect the valve for damage and foreign materials before connecting to the cylinder.
- Never drag, lift, or move a cylinder using the valve or the hand wheel as a handle.
- Never lubricate valves or their connections.
- Never move cylinders without the transport cap installed.
- Never tamper with regulatory or attempt to tighten or loosen the valve into or out of the cylinder.
- Never use a damaged valve where integrity may have been affected. Discontinue using a valve that operates abnormally, i.e., becomes noisy or progressively harder to operate.
- Never use an automatic operator, adapter, wrenches, or other tools to obtain a mechanical advantage on hand wheel-operated valves without reviewing all safety requirements.
- Open valves slowly to control pressure surges and heat of compression.
- Use the cylinder valve to regulate flow or pressure.

## Restrictive flow orifices | RFOs

Restrictive Flow Orifices are installed in the cylinder valve outlet and provides significant safety benefits for uses of hazardous gases including pyrophoric gases like silane. Consult the EHS Office for additional information on RFOs.

## Rupture disk

A rupture disk is a non-reclosing pressure relief device that protects a pressure vessel like a compressed gas cylinder from over pressurization or potentially damaging vacuum conditions. A rupture disc (also known as a bursting disc), is designed to provide a leak-tight seal within a pipe or vessel, until the internal pressure rises to a predetermined level. At that point the rupture disc bursts preventing damage to the equipment from overpressure.

## Vacuum pumps

Hydrocarbon based vacuum pump oil is incompatible with strongly oxidizing and many reactive gases. New vacuum pumps that have inert lubricants such as DuPont Krytox and never contained oil-based lubricants must be used with oxidizing and reactive gases.

Vacuum pumps must be securely vented to a fume hood or other approved exhaust system with

tubing that is compatible with the gases used. Exhaust lines must be as short as feasible. Vented enclosures may be required for vacuum pumps depending on the toxicity of the gases used.

### **Specific requirements of compressed gas cylinders**

Read the label on the cylinder and identify the contents before using. If the label is illegible or missing, return the cylinder to the supplier. Don't rely on stenciling or the color of the cylinder. Do not use a cylinder with unidentified contents. All cylinders must be permanently labeled as to their contents and if they are full or empty. For example, an empty cylinder may be marked "MT".

Empty cylinders must also be separated from full cylinders. Know the hazards of the contents and follow appropriate safe use practices for the material inside. Refer to the specific Safety Data Sheet, or SDS, for additional information.

Gases that have poor warning properties such as colorless, odorless, tasteless, non-irritating, odor threshold near the toxic level, or used in enclosed areas must be reviewed for exposure hazards. General or mechanical ventilation, personal badges, hand held monitors or sensors, room monitors, and/or environmental monitors should be considered. Delivery systems must be designed with auto shut-offs.

Specific requirements for flammable, toxic, highly toxic and pyrophoric gases are identified in Appendix F with examples of commonly used specialty gases identified in Appendix E. There are some exemptions for low concentrations of these gases where the manufacturer's Safety Data Sheet verifies the gas in question is no longer classified as toxic, flammable or pyrophoric or highly toxic. Highly toxic may only be exempted if the concentration is less than the applicable ACGIH threshold limit value.

### **Types of compressed gases**

The types of compressed gas can be divided into four categories, each with unique characteristics.

**Liquefied gas** can become liquid at normal temperatures when they are inside a cylinder under pressure. When gas is removed from the cylinder, enough liquid evaporates to replace it, keeping the pressure in the cylinder constant. Common examples include anhydrous ammonia, chlorine, propane, nitrous oxide, and carbon dioxide.

**Non-Liquefied gas** is also a compressed, pressurized or permanent gas. These gases do not become liquid when they are compressed at normal temperatures or even very high pressures. Common examples are oxygen, nitrogen, helium, and argon.

**Dissolved gas** can also be compressed. A common example of dissolved gas is acetylene. Care should be taken when using acetylene or welding. Consult your supervisor before using acetylene.

## Flammable, toxic, highly toxic and pyrophoric compressed gases

For the purposes of [EHS 122](#), "Compressed Gases," and this program, the following definitions apply:

**Flammable gas:** A gas that, at ambient temperatures and pressures, forms a flammable mixture with air at a concentration of less than thirteen (13) percent by volume; or forms a range of flammable mixtures with air wider than twelve (12) percent by volume.

**Pyrophoric gas:** A gas with an autoignition temperature in air at or below 130F.

**Toxic gas:** A gas that is a gas at room temperature; and has a median lethal dose (LD(50)) of more than 50 mg, but less than 500mg per kg of body weight when administered orally to albino rats weighing between 200 and 300 grams each; has an LD(50) of more than 200 mg/kg, but less than 1,000 mg/kg of body weight when administered by continuous contact for 24 hours (or less if death occurs within 24 hours) with the bare skin of albino rabbits weighing between two and three kilograms each; or has a median lethal concentration (LC(50)) in air of more than 200 PPM, but less than 2,000 PPM by volume or less when administered by continuous inhalation for one hour (or less if death occurs within one hour) to albino rats weighing between 200 and 300 grams each.

**Highly Toxic gas:** A gas that is a gas at room temperature; and has a median lethal dose (LD(50)) of 50 mg or less per kg of body weight when administered orally to albino rats weighing between 200 and 300 grams each; has a LD(50) of 200 mg/kg of body weight when administered by continuous contact for 24 hours (or less if death occurs within 24 hours) with the bare skin of albino rabbits weighing between two and three kilograms each; or has a median lethal concentration (LC(50)) in air of 200 PPM by volume or less when administered by continuous inhalation for one hour (or less if death occurs within one hour) to albino rats weighing between 200 and 300 grams each. Permanent installations of compressed gases must follow the CPMG permitting process and all [toxic and flammable compressed gas](#) cylinders must include the installation and maintenance of a gas cabinet approved by the ASU Fire Marshal.. See Appendix F

During the permit review process the ASU Fire Marshal's Office will specify installation requirements to include, but not limited to the following:

1. Gas cabinets are required for all toxic, highly toxic, pyrophoric and flammable compressed gas installations except as identified in Appendix F. Requirements for gas cabinets are identified in Appendix F.
2. Piping requirements such as those listed below.

Compressed gas piping, regulators, and flow control equipment must be:

- Bonded to minimize sparks due to static discharge when using flammable gas.
- Capable of withstanding gas supply pressures.
- Compatible with the chemical and physical properties of gas.
- Installed and operated by trained and qualified persons familiar with the specific hazards of the gases in use.
- Leak tested upon installation and monthly thereafter around valve and regulator connections, and fittings as identified in SOPs.



- Provided with a means for safely purging the system and devices to prevent backflow of gases or liquids into the gas storage cylinders when using hygroscopic corrosive gases, such as anhydrous hydrogen chloride.

All compressed gas cylinders must be fitted with a protective valve cap or guard while in storage unless the cylinder is not designed to accept a cap or guard. All cylinders must be secured in the upright position to prevent them from falling. If the use of small non-refillable cylinders is unavoidable, also known as lecture bottles, they should be secured in a device, cage, or box designed for cylinders 18" or smaller.

Portable flammable compressed gas systems must be approved either through the CPMG permitting process or through the use of the prior approval form identified in the [ASU Chemical Hygiene Program](#).

Approved uses of flammable compressed gases will be identified at the point of use by EHS or CPMG in evaluating regulatory compliance during inspections. Point-of-use identification will include approved gases and concentrations, quantity, and date of approval. A notice similar to that identified below will be placed at the point of use (hood, gas cabinet, or other permanent fixture) by EHS identifying the type(s) of gas and concentration range approved for use.

**ASU ARIZONA STATE UNIVERSITY**  
**APPROVED FOR USE** By Order of the **Arizona State University Fire Marshal and Building Official**

Description: \_\_\_\_\_

Bldg Name & # \_\_\_\_\_

Date: \_\_\_\_\_ PERMIT/EH&S# \_\_\_\_\_

Fire Official \_\_\_\_\_ Building Official \_\_\_\_\_

UNDER PENALTY OF LAW DO NOT REMOVE THIS NOTICE  
 ASU FIRE MARSHAL OFFICE 480-955-1823/ASU BUILDING OFFICIAL OFFICE 480-727-7100

## Cryogenic liquids

All cryogenic liquids should be used with caution due to the potential for skin or eye damage due to the low temperature, and the hazards associated with pressure buildups in enclosed piping or containers. Special hand/arm protection includes the use of cryogenic gloves; these gloves should be loose fitted and are designed to protect human tissue from cold burns.

Personal protective equipment includes a full face shield, full foot cover and clothing that prevent the absorption of liquids such as thick sweater, jackets and pants with cuffs for transferring cryogenic fluids.

Portable containers should only be used where there is sufficient ventilation. Do not place containers in a closet or other enclosed space where there is no ventilation supply to the area. The buildup of inert gas in such an area could generate an oxygen deficient atmosphere.

Special vacuum jacket containers with loose fitting lids should be used to handle small quantities. Vacuum jacketed containers provided by the gas supplier will have overpressure relief devices in place.

Any space where cryogenic fluids may accumulate (consider leakage into enclosed equipment) must be vented or protected by overpressure relief devices. Tremendous pressures can result in enclosed spaces as the liquid converts to gas. For example, one cubic centimeter of liquid nitrogen will expand to 700 times this volume as it converts or warms to its gaseous state.

Containers to be filled with cryogenic liquids should be filled slowly to avoid splashing.

Cryogenic containers showing evidence of loss of vacuum in their outer jacket – ice buildup on the outside of the container – should not be accepted from the gas supplier. Contact with air, or gases with a higher boiling point, can cause an ice plug in a cryogenic container.

### **Dewar safety**

See Appendix B on Dewar Safety

### **Inerts, oxidizers, pyrophoric or toxic compressed gas cylinders**

Consult the Safety Data Sheet for all gases. Some gases are pyrophoric (phosphine), corrosive (hydrogen chloride), toxic (ethylene oxide), anesthetic (nitrous oxide), or highly reactive (anhydrous ammonia). Call EHS at 480-965-1823 if you are unsure how to control the dangerous properties of a particular compressed gas.

#### **Inerts**

Inerts such as Nitrogen is a gas that makes up about 78% of the air we breathe. Nitrogen is a dry, inert, colorless and odorless gas; it is nonflammable and noncorrosive. Even with these somewhat minor hazard characteristics, inert gases cause numerous emergency incidents each year. Care must be taken to prevent oxygen deficient atmosphere, equipment that used Nitrogen or other inerts should use mechanical ventilation or exhaust monitoring to prevent asphyxiation in compliance with IFC 5307.2.

- Carbon Dioxide must be treated with caution. If left to leak into closed space, these gases may displace oxygen and create a risk of asphyxiation.

## **Oxidizers**

- Oxidizing gases such as compressed oxygen or nitrous oxide, while not combustible themselves, will cause many materials to burn violently. Never use grease, solvents, or other flammable material on an oxygen valve, regulator, or piping. Oxidizer use and storage shall comply with IFC Chapter 63.
- Anesthetic gas may cause loss of sensation with or without the loss of consciousness and the storage handling and use of these type materials must follow these requirements.

## **Flammables**

- Flammable gases such as propane, hydrogen, and acetylene always have a red label. However, the color of the cylinder itself is not a good indicator of flammability as different distributors may use different colored cylinders for the same gas. Check the label for flammability.
- The flammable range of a gas, including all concentrations in air between the Lower Flammable Limit (LFL) and the Upper Flammable Limit (UFL) needs to be recognized. For example, the flammable range for hydrogen is an LFL = 4% and an UFL = 75%.
- The auto-ignition temperature is the minimum temperature that gas and its vapors can spontaneously ignite in air. Examples include Silane or Diborane.
- Flammable gas must be segregated from oxidizers and shall comply with IFC Chapter 57.

**Pyrophoric** – Hazardous gas (arsine, silane, phosgene, diborane, etc.) cylinders should be stored in a suitable exhausted location in compliance with IFC Chapter 64 with gas detection as specified in this program. If a hazardous gas cylinder develops a leak, evacuate and restrict area access.

**Toxic** – gas use may require the use to toxic gas monitoring, handling, storage and emergency procedures as well as additional facility considerations in compliance with IFC Chapter 60. A Process Hazard Assessment must be completed before a toxic gas can be used. Specific operating procedures must be developed and reviewed annually per the Chemical Hygiene Plan. Contact EHS if you plan to use these gases.

**Reporting requirements** – Maintain constant awareness of and respect for compressed gas cylinders and equipment. Comply with all applicable ASU safety rules and compliance with all applicable ASU EHS rules are mandatory.

- Accidents must be reported and any injury must follow ASU injury reporting requirements.
- Employees shall report any safety concerns to their supervisor or EHS.
- Report all suspected leaks immediately. If the material in the cylinder is toxic, highly toxic, flammable, or pyrophoric and you suspect a leak, evacuate everyone out of the area and report it to the appropriate person in your department.
- Representatives of the EHS Office, including EHS Compliance Officers and Compressed Gas Safety Training mentors are available to observe work practices and may periodically audit work practices. If unsafe work practices are observed, they will communicate their observations to affected employees and assist with preventing unsafe work from continuing.

## **Compressed gas cylinder emergencies**

- Emergencies involving compressed gases are unlikely, provided the recommendations are followed for their correct storage, handling, and use. When problems do arise they are usually due to:
  - Fire threatening the cylinder.
  - Toxic or inert gas leaks.
  - Unplanned chemical or other reaction.
- Most leaks occur at the valve and valve stem fitted on the top of the cylinder. Leakage here is frequently due to dirt in the connection, or damaged connections or washers where required. Such leaks are easily rectified. Attempt to tighten the connection.

If cylinders are involved in any type of an emergency, and it's safe to do so, isolate the gas outdoors and away from sparks and heat. In any event all defective cylinders should be clearly labeled and returned to the supplier.

## Appendix A

### Definitions

**Anesthetic gas** – A gas that may cause loss of sensation with or without the loss of consciousness.

**Check Valve** – Check valves are mechanical valves that permit gases and liquids to flow in only one direction, preventing process flow from reversing. Must be provided when the backflow of hazardous materials could create a hazardous condition or accidental discharge of hazardous gases.

**CGA** – Compressed Gas Association

**Corrosive Gas** – A gas that can cause visible destruction of, or irreversible alterations in, living tissue (e.g., skin, eyes, or respiratory system) by chemical action.

**Cryogenic Liquids** – Gases condensed to liquid form at extremely low temperatures. Example: Liquid Nitrogen is  $-196^{\circ}\text{C}$  ( $-320^{\circ}\text{F}$ ). The term “cryogenics” applies to all temperatures less than  $-150^{\circ}\text{C}$  ( $-238^{\circ}\text{F}$ ).

### Compressed Gas –

- A gas or mixture of gases in a container, having an absolute pressure exceeding 40 psi at  $70^{\circ}\text{F}$  ( $21.1^{\circ}\text{C}$ ) or
- A gas or mixture of gases in a container, having an absolute pressure exceeding 104 psi at  $130^{\circ}\text{F}$  ( $54.4^{\circ}\text{C}$ ) regardless of the pressure at  $70^{\circ}\text{F}$  ( $21.1^{\circ}\text{C}$ ) or
- A liquid having a vapor pressure exceeding 40 psi at  $100^{\circ}\text{F}$  ( $37.8^{\circ}\text{C}$ ) as determined by ASTM D-323-72.

**Corrosive or Corrosive Material** – As defined by the Department of Transportation, or DOT, a corrosive material is a liquid or solid that causes visible destruction or irreversible alterations in human skin tissue at the site of contact or in the cases of leakage from its packaging, a liquid that has a severe corrosion rate on steel

**DOT** – U.S. Department of Transportation.

**Excess flow control** – can be achieved by leak detection and emergency shut off or by an excess flow control device.

**Fire Detection** – UV/IR sensor, high sensitivity smoke detection, rate of rise temperature sensors provided in cabinets or installations containing pyrophoric gas.

**Flammable gas** – A gas that can be ignited in air.

**Flammable** – A chemical that falls into one of the following categories:

- Aerosol, flammable: Means an aerosol that, when tested by the method described in 18 CFR 1500.45, yields a flame projection exceeding 18 inches at full valve opening, or a flashback (a flame extending back to the valve) at any degree of valve opening
- Gas, flammable:
  - A gas that at ambient temperature and pressure forms a flammable mixture with air at a concentration of 13 percent by volume or less.
  - A gas that, at ambient temperature and pressure, forms a range of flammable mixtures with air wider than 12 percent by volume, regardless of the lower limit.

**Definition from EHS 122 – Flammable gas:** A gas that, at ambient temperatures and pressures, forms a flammable mixture with air at a concentration of less than thirteen (13) percent by volume; or forms a range of flammable mixtures with air wider than twelve (12) percent by volume.

- Liquid, flammable: Any liquid having a flashpoint below 100 °F (37.7 °C), except any mixture having components with flashpoints of 100 °F (37.7 °C) or higher, the total of which make up 99 percent or more of the total volume of the mixture.
- Solid, flammable: A solid, other than a blasting agent or explosive as defined in § 1910.109 (a), that is liable to cause fire through friction, absorption of moisture, spontaneous chemical change, or retained heat from manufacturing or processing, or which can be ignited readily and when ignited burns so vigorously and persistently as to create a serious hazard. A chemical must be considered to be a flammable solid if, when tested by the method described in 16 CFR 1500.44, it ignites and burns with a self- sustained flame at a rate greater than one-tenth of an inch per second along its major axis.

**Flammable limits** – The concentration of flammable vapor in air, oxygen, or other oxidants that will propagate flame upon contact when provided with a source of ignition. The lower explosive limit (LEL) is the concentration below which a flame will not propagate; the upper explosive limit (UEL) is the concentration above which a flame will not propagate. A change in temperature or pressure may vary the flammable limits.

**Flashpoint** – The minimum temperature at which a liquid gives off a vapor in sufficient concentration to ignite when tested as follows:

- Organic peroxides, which undergo auto accelerating thermal decomposition, are excluded from any of the flashpoint determination methods specified below.
- Pensky-Martens Closed Tester (see American National Standard Method of Test for Flash Point by Pensky-Martens Closed Tester, Z11.7-1979 (ASTM D 93-79))-for liquids with a viscosity equal to or greater than 45 SUS at 100 °F (37.8 °C), or that contain suspended solids, or that have a tendency to form a surface film under test.
- Setaflash Closed Tester (see American National Standard Method for Test for Flash Point by Setaflash Closed Tester (ASTM D 3278-78)).
- Tagliabue Closed Tester (See American National Standard Method of Test for Flash Point by Tag Closed Tester, Z11.24-1979 (ASTM D 56-79))-for liquids with a viscosity of less than 45 Saybolt Universal Seconds (SUS) at 100 °F (37.8 °C), that do not contain suspended solids and do not have a tendency to form a surface film under test.

**Gas cabinet** – designed to provide an exhausted enclosure for gas cylinders. Required for all toxic, highly toxic, pyrophoric and flammable gas cylinders. Must meet the following:

1. Constructed of 12-gauge steel.
2. Be provided with self-closing limited access ports or windows to give access to controls.
3. Self-closing doors.
4. Treated, coated or constructed of materials compatible with materials stored.
5. Exhaust ventilation to provide 200 linear feet per minute across open access port.

See Appendix F for specifications.

**Hazardous gas** – A gas that is included in one or more of the following hazard categories: corrosive, flammable, health hazard, oxidizer, pyrophoric, reactive, or toxic. See Appendix F for use and handling requirements.

**Health Hazard** – Any chemical for which there is at least one scientific study that shows it may cause acute or chronic health symptoms. This includes chemicals which are carcinogens, toxic or highly toxic, irritants, corrosives, sensitizers, or chemicals that effect target organs including the lungs, kidneys, nervous system, pulmonary system, reproductive system, skin, and/or eyes.

**Highly Toxic Gas:** A gas that is a gas at room temperature; and has a median lethal dose (LD(50)) of 50 mg or less per kg of body weight when administered orally to albino rats weighing between 200 and 300 grams each; has a LD(50) of 200 mg/kg of body weight when administered by continuous contact for 24 hours (or less if death occurs within 24 hours) with the bare skin of albino rabbits weighing between two and three kilograms each; or has a medium lethal concentration (LC(50)) in air of 200 PPM by volume or less when administered by continuous inhalation for one hour (or less if death occurs within one hour) to albino rats weighing between 200 and 300 grams each.

**Ignition Source** – Anything that provides heat, sparks, or flame sufficient to cause combustion/explosion.

**Inerts** – Gases that do not readily reactive with other elements; forming few or no chemical compounds.

**Incompatible** – Materials which could cause dangerous reactions from direct contact with one another.

**Laboratory** – A laboratory is defined as a facility or room where the use of potentially hazardous chemicals, biological agents, or sources of energy (i.e. lasers, high voltage, radiation, etc.) are used for scientific experimentation, research, or education.

**Lower Explosive Limit, LEL** – is the lowest concentration of a gas or vapor in the air that can produce ignition or explosion.

**Mass Flow Controller, MFC** – is a device used to measure and control the flow of gases.

**Safety Data Sheet, SDS** – Written or printed material about a chemical that specifies its hazards, safe use and other information. It is prepared by the chemical manufacturer, and is required by federal law.

**Mechanical Exhaust** – Mechanical exhaust systems use a powered device, such as a motor-driven fan or air/street venturi tube, for exhausting contaminants from a workplace, vessel, or enclosure.

**NFPA** – National Fire Protection Association.

**OSHA** – The Occupational Safety and Health Administration of the U.S. Department of Labor is a federal agency with safety and health enforcement authority for most of U.S. industry and business.

**Oxidizer** – Department of Transportation defines oxidizer or oxidizing material as a substance that yields oxygen readily to stimulate the combustion (oxidation) of organic matter. Chlorate ( $\text{ClO}_3$ ), permanganate ( $\text{MnO}_4$ ) and nitrate ( $\text{NO}_3$ ) compounds are examples of oxidizers.

**Oxidizing gas** – A gas that initiates or promotes combustion in materials, either by catching fire itself or by potentially causing a fire through the release of oxygen or other gases.

**Oxygen deficiency** – A condition that occurs when a breathable atmosphere contains less than 19.5% oxygen. Note: Normal air contains 20.8% oxygen.

**Physical hazard** – A chemical for which there is scientifically valid evidence that it is a combustible liquid, a compressed gas, an explosive, a flammable, an organic peroxide, an oxidizer, a pyrophoric, an unstable (reactive), or a water-reactive.

**Purge panel** – system to evacuate or purge lines of hazardous gases to facilitate safe cylinder removal and installation.

**Pyrophoric gases** – Gases that may spontaneously ignite in air at or below 54 °C (130 °F). Specific gases may not ignite in all circumstances or may explosively decompose.

**Restrictive Flow Orifice, RFO** – A safety device placed in the outlet of a cylinder valve that is intended to limit the release rate of a hazardous gas to a maximum specified range in the event of the inadvertent opening of the valve, or failure of the system downstream of the valve outlet.

**STP** – In chemistry, Standard Temperature and Pressure or STP is defined as 0 °C (32 °F) and 1 atmosphere of pressure (101.325 kPa or 29.92 inches of mercury).

**Toxic gas** – A gas that is poisonous or capable of causing injury or death, especially by chemical means. As defined in EHS 122: Compressed Gases a **Toxic Gas** is a gas that is a gas at room temperature; and has a median lethal dose (LD(50)) of more than 50 mg, but less than 500 per kg of body weight when administered orally to albino rats weighing between 200 and 300 grams each; has a LD(50) of more than 200 mg/kg, but less than 1,000 mg/kg of body weight when administered by continuous contact for 24 hours (or less if death occurs within 24 hours) with the bare skin of albino rabbits weighing between two and three kilograms each; or has a medium lethal concentration (LC(50)) in air of more than 200 PPM, but less than 2,000 PPM by volume or less when administered by continuous inhalation for one hour (or less if death occurs within one hour) to albino rats weighing between 200 and 300 grams each.

**Upper Explosive Limit, UEL** – The highest concentration of a gas or vapor in air that can produce ignition or explosion.



**Treatment system** – For Toxic and Highly Toxic gases, a treatment system will be installed when required by IFC 6004.2. These systems are designed to handle an accidental release of a full cylinder of gas and reduce the maximum allowable discharge concentrations to one half immediately dangerous to life and health concentrations at the point of discharge to atmosphere. If the cylinder is equipped with a restrictive flow orifice, (RFO) the release rate will be calculated by the maximum flow from the valve as determined by the manufacturer. If not equipped with a RFO, release rate will be 5 minutes for nonliquefied gases and 30 minutes for a liquefied gas.

**Unstable, or reactive** – An unstable or reactive chemical can go through vigorous polymerization, decomposition or condensation. This process occurs when the chemical undergoes shock or changes in pressure or temperature.

**Water reactive** – A chemical that reacts with water to release a gas that is either flammable or presents a health hazard.

## Appendix B

### General Guidelines for Flammable Gases

The volume of flammable gas in a lab, room or location is restricted by University guidelines and International Fire Codes. EHS should be contacted regarding any questions or for additional guidance.

The volume of flammable gas shall be kept to the minimum necessary for the work being done. Just in time delivery should be used where possible.

The maximum internal volume (water volume) of all cylinders in each of the listed classifications, in use in the laboratory work area or single fire area, shall comply with the following based on internal cylinder volume at 70 °F (21 °C).

For a laboratory work area of 500 ft<sup>2</sup> or less, the internal cylinder volume equals 6.0 ft<sup>3</sup> or approximately three (3) "K" (9.25 inch diameter, 60 inch height) sized cylinders.

For a laboratory work area greater than 500 ft<sup>2</sup>, the internal cylinder volume is 0.012 ft<sup>3</sup> per ft<sup>2</sup> lab work area, but not to exceed the maximum cubic feet of gas from the chart below (approximately five (5) "K" sized cylinders for flammable gas except hydrogen – see Section 4).

Material	Storage	Use-Closed System	Use-Open System
	Cubic Feet	Cubic Feet	Cubic Feet
Oxidizing Gas	1,500	1,500	NA
Flammable Gas	1,000	1,000	NA
Pyrophoric Gas	50	10	NA

The maximum quantity of lecture bottles in a single fire control area should not exceed 20. AS U strongly discourages the use of any non-returnable, non-refillable compressed gas cylinders or lecture bottles.

Flammable gasses should be separated by 20 ft. (6.1 m) from all pyrophoric, oxidizing and corrosive gases except as follows:

The 20 ft. distance shall be reduced without limit when separated by a barrier of noncombustible materials at least 5 ft. (1.5 m) high that has a fire resistance rating of at least 30 minutes.

The 20 ft. distance shall be reduced to 5 ft. where one of the gases is enclosed in a gas cabinet or without limit where both gases are enclosed in gas cabinet.

Cylinders without pressure-relief devices shall be stored separately from flammable and pyrophoric gases with pressure-relief devices.

**The following are requirements for outdoor storage of flammable gas:**

- All compressed gas cylinders shall be stored in an upright position.
- All flammable gas cylinders, full or empty, shall be handled in the same manner. Store empty cylinders separately from full cylinders.
- Always use non-sparking tools on compressed gas cylinders.
- Compressed flammable gas cylinders shall not be exposed to dampness, salt, corrosive chemicals or fumes that could damage the cylinders or valve-protective caps.
- Compressed flammable gas cylinders should not be placed where they could become a part of an electrical circuit.
- Compressed flammable gas cylinders, whether full or partially full, shall not be exposed to or heated by devices that could raise the temperatures above 125 °F (52 °C).
- Cylinders stored outside shall not be placed on the ground (earth) or on surfaces where water can accumulate.
- Leaking, damaged, or corroded compressed flammable gas cylinders should be removed from service.
- Signs should be posted in areas containing flammable gases communicating that smoking or the use of open flame, or both, is prohibited within 25 ft of the storage or use area perimeter.
- Static-producing equipment located in flammable gas areas shall be grounded.
- Storage areas shall be kept clear of dry vegetation and combustible materials for a minimum distance of 15 ft.
- Storage areas shall be permitted to be covered with canopies of noncombustible construction.
- Storage areas shall be provided with physical protection from vehicle damage.
- The cylinders should not be stored within 10 ft of windows, doors, or other openings nor shall they be stored within 50 ft of ventilation intakes.

## Hydrogen

Hydrogen gas has several unique properties that make it potentially dangerous. It has an extremely wide flammability range (LEL 4%, UEL 74.5%) that makes it easier to ignite than most flammable gases. Unlike most other gases, hydrogen's temperature increases during expansion. Many hydrogen fires result from the self-ignition of sudden hydrogen release through rupture disks and pressure relief valves.

### Observe the following guidelines for hydrogen use and storage:

- Adequate ventilation should be provided and maintained throughout the area where hydrogen cylinders are in use.
- For gaseous hydrogen service, joints in piping and tubing should be made by welding or brazing or by use of flanged, threaded, socket, slip, or compression fittings. Brazing materials should have a melting point above 1000 °F (538 °C).
- Gas cabinets are required where new installations of hydrogen cylinders are in use.
- Hydrogen burns with an invisible flame. Caution should therefore be exercised when approaching a suspected hydrogen flame.
- Hydrogen embrittlement can weaken carbon steel, therefore cast iron pipes and fittings should not be used.
- Limit the number of hydrogen cylinders being stored in the lab when not in use.
- Locate the cylinders 25 ft from open flames and other sources of ignition.
- Open the cylinder valve slowly. If a cylinder valve is opened too quickly, the static charge generated by the escaping gas may cause it to ignite.
- Piping, tubing, fittings, gaskets, and thread sealants should be suitable for hydrogen service at the pressures and temperatures involved. Refer to American Society of Mechanical Engineers Code for Process Piping, ASME B31.3.
- Provide 20 ft of separation from Class I, II and IIIA flammable liquids, oxidizing gases and readily combustible materials.
- Provide 50 ft of separation from other flammable gas storage.

## Acetylene

Acetylene is flammable gas with a normal explosive range with air of 2.3 to 80% acetylene. Special cylinders used for acetylene contain a porous material and acetone, in which the gas dissolves and becomes practically stable. The porous filler absorbs the acetone and eliminates large voids in which decomposition might occur. Because of its tendency to break down and release energy, acetylene is highly reactive and is widely used in chemical processes. The temperature of the oxyacetylene flame, 5400 to 6300 °F (3000 to 3500 °C), is the highest for any commercially practical mixture of gases.

The minimum autoignition temperature for acetylene-air mixtures is about 571 °F (300 °C). The presence of catalytic impurities such as rust, scale, silica gel, charcoal, or potassium hydroxide can lower the ignition temperature substantially. The presence of copper, silver, or mercury acetylides combined with light shock can result in ignition or decomposition of acetylene at room temperatures.

### Observe the following guidelines for acetylene use and storage:

- Do not handle cylinders roughly, subject cylinders to hydrostatic test, or take any other action that can create large voids in the mineral filler.
- Do not withdraw acetylene from a cylinder or manifold at a rate in excess of one-seventh of the total cylinder capacity per hour. Provide additional cylinders if needed to supply higher demand without exceeding this rate.
- Keep acetylene cylinder valves closed when gas is not being used, and open the valves only 1-1/2 turns when in use.
- Provide separate storage locations for acetylene and oxygen or chlorine cylinders. A gas-tight non-combustible partition will serve to separate a storage area for this purpose.
- Store and use cylinders in an upright position to prevent loss of acetone.
- Use a pressure regulator at the discharge of an individual cylinder or manifold to reduce the gas pressure to 15 psi (105 kPa) or less.
- Use wrought-iron or steel pipe and steel or malleable-iron fittings. Welded joints are preferable because of the reduced probability of leakage. Alloys containing more than 67% copper should not be used for piping, valves, or fittings (with the exception of a torch tip, which is pure copper).

## **Liquefied petroleum gas – LPG**

- Although Liquefied Petroleum Gases, or LPG, are transported and stored as liquids, they are gases at atmospheric pressures and normal temperatures. They are as hazardous as other combustible gases, with the added danger that they are heavier than air, tend to remain in low places for a somewhat longer period, and have little or no natural odor.
- The discharge from tank relief valves, if ignited, can create a large torch fire. The intense, radiated heat may seriously expose buildings and contents. If ignition is delayed, the discharge from tank relief valves may travel hundreds of feet and settle in low-lying areas or enter below grade building openings. If the gas enters a building, ignition may result in an explosion. Once ignited, the resulting flashback to the tank may involve other structures and contents.

### **Observe the following guidelines for LPG use and storage:**

- All cylinders having a propane capacity of 4 pounds through 40 pounds fabricated after 1998 must be equipped with an overfill prevention device, or OPD, as a secondary means of protecting against overfilling (the primary means is to determine the fill limit by weight). Cylinders equipped with OPD's will have a triple-notched valve hand wheel with the letters "OPD."
- Containers of LPG should be stored outside of buildings at least 10 ft. from any doorway or other opening with the following exceptions. For temporary demonstration purposes, a container with a maximum water capacity of 12 pounds (5 pounds of LPG) may be used. For hand torches or similar appliances, a container with a maximum water capacity of 2.5 pounds (1 pound of LPG) may be used.
- Cylinders should not be filled past their rated capacity. The weight limit is usually specified on the cylinder. If it has been overfilled, the pressure relief valve may release propane as the cylinder warms. Overfilling can lead to flash fires and explosions.
- Cylinders that are visibly rusted or damaged shall not be refilled.
- Never use propane from a cylinder without a regulator (except for forklift cylinders). Protect the regulator connector from scratches and dents. Ensure the regulator vent is clean and pointed downward, and the regulator is protected.
- The cylinders should be kept in a secure upright position with the valves closed and the thread caps secured when they are transported, stored, or used.
- Used cylinders must be retrofitted with UL listed OPD's when being re-qualified

under DOT regulations. Affected cylinders cannot be filled unless they are equipped with UL listed OPD's. Cylinders should be kept away from heat sources, as the heat can build up pressure inside the cylinder and may cause the pressure relief valve to release propane.

- When disconnecting cylinders, whether full or empty, first close the shut-off valve, then disconnect the cylinder and snugly seal the valve with a plug, cap, or approved quick-closing coupling.

## Oxygen

Oxygen is neither combustible nor explosive. However, the intensity of any ordinary fire or explosion increases as the amount of oxygen in the surrounding air increases. Materials, such as grease or oils that produce intense fires with air, burn in an atmosphere of enriched oxygen with explosive violence. Explosions have occurred in oxygen pressure gauges after being tested on common oil-filled gauge testers. Oxygen at atmospheric pressure in a closed system can combine explosively with lubricating oil at temperatures above 340 °F (170 °C).

### Observe the following guidelines for oxygen use and storage:

- Compounds containing oils should not be used. Gaskets should be entirely of noncombustible materials.
- Do not use oil or grease for lubricating valves, gauge connections, or other parts of the oxygen system.
- In medical oxygen gas systems, Type K or L (ASTM B-88) copper tubing may be used. Brazed fittings should be used for 3/4-inch (19-mm) and larger tubing. Flared-type tubing fittings may be used in smaller sizes where the fitting is visible in the room.
- Separate oxygen cylinders from cylinders or manifolds containing flammable gases and other combustible or easily ignited materials such as wood, paper, oil, and grease. Gas-tight fire partitions having at least 1/2 hour fire resistance rating are suitable as cutoffs. **Note:** This does not apply to properly arranged and safeguarded oxygen and acetylene tanks used for cutting and welding torches.
- Use extra-heavy steel or nonferrous pipe and fittings if the oxygen pressure is over 150 psi (1 MPa). For lower pressures, standard-weight pipe and fittings are satisfactory. Cast-iron fittings should not be used.
- Use welded joints whenever possible. If threaded joints are necessary, they should be carefully made using litharge and glycerin or proprietary materials compounded for oxygen service.

## Pyrophoric gas

Pyrophoric chemicals are those substances that react so rapidly with air and its moisture that the ensuing oxidation and/or hydrolysis lead to ignition. Ignition may be instantaneous or delayed. Spontaneous (instantaneous) ignition or combustion occurs when a substance reaches its ignition temperature without the application of external heat.

An example of a pyrophoric gas is silane. Silane has caused major losses due to fires in ducts, gas cabinets, and supply systems; and explosions in ducts, vacuum pumps, and cross-contaminated cylinders. These incidents have occurred in research facilities. The hazards are pyrophoric fires, explosions, and/or deflagrations, and autoignition of a vapor cloud. All of these conditions can occur depending on leak location, excess flow control and shutdown of the silane gas. Pyrophoric fires are difficult to extinguish. When pyrophoric fires are extinguished, the gas supply must be shut down promptly by interlocks tied into fire protection and/or detection, because resulting pyrophoric gas build up has the potential to create vapor cloud detonation.

### **Observe the following guidelines when storing or using pyrophoric gas:**

- All process systems components and equipment should be adequately purged using a dedicated inert gas cylinder.
- Emergency back-up power should be provided for all electrical controls, alarms, and safeguards associated with the storage and process systems.
- Minimally-sized cylinders of pyrophoric gases shall be limited per the table above unless otherwise specified in the permit review and kept in approved gas cabinets.
- Order cylinders with the smallest orifice as practicable, 0.006 inch and not to exceed 0.010 inch.
- Pyrophoric gas flow, purge, and exhaust systems should have redundant controls that prevent pyrophoric gas from igniting or exploding. These controls include excess flow valves, flow orifices, mass flow controller sizing, process bypass line elimination or control, vacuum-pump inert-gas purging, dilution of process effluent with inert gas and ventilation, controlled combustion of process effluent, ventilation monitoring, and automatic gas shutdown.
- Remote manual shutdown devices for pyrophoric gas flow should be provided outside each gas cabinet or near each gas panel. Automatic shutdown devices for pyrophoric gas flow activated by interlocks tied into fire protection and/or detection should be provided and may be required in the permit review.



## Appendix C

### Dewar Safety

Dewars usually have nitrogen as its common content. Contact of liquid nitrogen or any very cold gas with the skin or eyes may cause serious freezing (frostbite) injury. Protect hands at all times when working with liquid nitrogen.

### Handle Liquid Nitrogen carefully

The extremely low temperature can freeze human flesh very rapidly. When spilled on a surface the liquid tends to cover it completely and immediately, cooling a large area.

The gas issuing from the liquid is also extremely cold. Delicate tissue, such as that of the eyes, can be damaged by an exposure to the cold gas which would be too brief to affect the skin of the hands or face.

### Never allow any unprotected skin to touch objects cooled by liquid nitrogen:

Such objects may stick fast to the skin and tear the flesh when you attempt to free yourself. Use tongs, preferable with insulated handles, to withdraw objects immersed in the liquid, and handle the object carefully.

### Protective clothing

Protect your eyes with face shield or safety goggles (safety glasses without side shields do not give adequate protection). Always wear cryogenic gloves when handling anything that is, or may have been, in immediate contact with liquid nitrogen. The gloves should fit loosely, so that they can be thrown off quickly if liquid should splash into them. When handling liquid in open containers, it is advisable to wear high-top shoes. Trousers (which should be cuffless if possible) should be worn outside the shoes.

Any kind of canvas shoes should be avoided because a liquid nitrogen spill can be taken up by the canvas resulting in a far more severe burn.

### Approved Containers for low-temperature liquids

Cryogenic containers are specifically designed and made of materials that can withstand the rapid changes and extreme temperature differences encountered in working with liquid nitrogen. Even these special containers should be filled *slowly* to minimize the internal stresses that occur when any material is cooled. Excessive internal stresses can damage the container.

Do not ever cover or plug the entrance opening of any liquid nitrogen dewar. Do not use any stopper or other device that would interfere with venting of gas.

These cryogenic liquid containers are generally designed to operate with little or no internal

pressure. Inadequate venting can result in excessive gas pressure which could damage or burst the container.

Use only the loose-fitting necktube core supplied or one of the approved accessories for closing the necktube. Check the unit periodically to be sure that venting is not restricted by accumulated ice or frost.

### **Proper transfer equipment**

Use a phase separator or special filling funnel to prevent splashing and spilling when transferring liquid nitrogen into or from a dewar. The top of the funnel should be partly covered to reduce splashing. Use only small, easily handled dewars for pouring liquid. For the larger, heavier containers, use a cryogenic liquid withdrawal device to transfer liquid from one container to another. Be sure to follow instructions supplied with the withdrawal device. When liquid cylinders or other large storage containers are used for filling, follow the instructions supplied with those units and their accessories.

### **Avoid overfilling containers**

Filling above the bottom of the necktube (or specified maximum level) can result in overflow and spillage of liquid when the necktube core or cover is placed in the opening.

### **Never use hollow rods or tubes as dipsticks**

When a warm tube is inserted into liquid nitrogen, liquid will spout from the bottom of the tube due to gasification and rapid expansion of liquid inside the tube. Wooden or solid metal dipsticks are recommended; avoid using plastics that may become very brittle at cryogenic temperatures which then become prone to shatter like a fragile piece of glass.

### **Nitrogen gas can cause suffocation without warning. Store and use liquid nitrogen only in a well ventilated place.**

- As the liquid evaporates, the resulting gas tends to displace the normal air from the area. In closed areas, excessive amounts of nitrogen gas reduces the concentration of oxygen and can result in asphyxiation. Because nitrogen gas is colorless, odorless and tasteless, it cannot be detected by the human senses and will be breathed as if it were air. Breathing an atmosphere that contains less than 18 percent oxygen can cause dizziness and quickly result in unconsciousness and death.

#### **Note:**

- Do not pour the liquid on the pavement.
- Never dispose of liquid nitrogen in confined areas or places where others may enter.

Disposal of liquid nitrogen should be done outdoors in a safe place. Pour the liquid slowly on gravel or bare earth where it can evaporate without causing damage.

- The cloudy vapor that appears when liquid nitrogen is exposed to the air is condensed moisture, not the gas itself. The gas actually causing the condensation and freezing is completely invisible.

### **First aid**

- If a person seems to become dizzy or loses consciousness while working with liquid nitrogen, move to a well-ventilated area immediately. If breathing has stopped, contact 911 immediately and apply artificial respiration. If breathing is difficult, give oxygen. . Keep warm and at rest.
- If exposed to liquid or cold gas, restore tissue to normal body temperature 98.6 °F (37 °C) as rapidly as possible, followed by protection of the injured tissue from further damage and infection. Remove or loosen clothing that may constrict blood circulation to the frozen area. Call a physician. Rapid warming of the affected part is best achieved by using water at 108 °F/42 °C).
- Most liquid nitrogen burns are really bad cases of frostbite. This is not to belittle the harm that can come from frostbite, but at the same time, it's important to keep the dangers associated with liquid nitrogen burns in perspective. Indeed, liquid nitrogen burns could be treated as frostbite.
- Under no circumstances should the water be over 112 °F/44 °C, nor should the frozen part be rubbed either before or after rewarming. The patient should neither smoke, nor drink alcohol.

### **Handling liquid nitrogen dewars:**

- Do not place these units in closed vehicles where the nitrogen gas that is continuously vented from unit can accumulate. Prevent spillage of liquids and damage to unit by securing it in the upright position so that it cannot be tipped over. Protect the unit from severe jolting and impact that could cause damage, especially to the vacuum seal.
- Dropping the container, allowing it to fall over on its side, or subjecting it to sharp impact or severe vibration can result in partial or complete loss of vacuum. To protect the vacuum insulation system, handle containers carefully. Do not "walk", roll or drag these units across a floor. Use a dolly or handcart when moving containers, especially the larger portable refrigerators. Large units are heavy enough to cause personal injury or damage to equipment if proper lifting and handling techniques are not used.
- Keep unit upright at all times except when pouring liquid from Dewars specifically designed for that purpose.

- Rough handling can cause serious damage to dewars and refrigerators.
- Tipping the container or laying it on its side can cause spillage of liquid nitrogen. It may also damage the container and any materials stored in it.
- When transporting contents from a liquid nitrogen dewar, maintain adequate ventilation and protect the unit from damage.

**Keep the unit clean and dry**

- Do not store it in wet, dirty areas. Moisture, animal waste, chemicals, strong cleaning agents, and other substances which could promote corrosion should be removed promptly. Use water or mild detergent for cleaning and dry the surface thoroughly.
- Do not use strong alkaline or acid cleaners that could damage the finish and corrode the metal shell.

## Appendix D

### Gas Monitoring and Detection

Use of flammable and highly toxic compressed gases, as defined in this guideline, that are not considered a closed system, must be used within ventilated enclosures such as a laboratory hood or glove box, or the use of real time gas detection may be required as follows. The use of emission control devices such as burn boxes or scrubbers will be addressed as part of the permit review process or the Prior Approval Process as applicable.

Exception: Acetylene may be used in designated hot work areas approved by the Campus Fire Marshal without the use of real time gas detection. However, whenever mobile units are carried into confined spaces, gas monitoring for flammable gases and oxygen must be conducted as required under the ASU Confined Space Entry Program.

#### Flammable and Highly toxic gases

Gas detection will be installed at the storage location (typically within a gas cabinet) and within the room conveying the flammable gas unless the tubing used to convey the gas from its storage location to the point of use is continuous non-combustible tubing (orbital welds only unless a variance is granted, no fittings), or all fittings are contained within a manifold equipped with local exhaust ventilation, that has been leak checked. Gas detection within the room itself, if required, should be placed at location likely to detect any leakage such as near an air return. Flammable gas detection shall comply with IFC Chapters 53 and 58 while toxic gas detection must comply with IFC 6004.2.2.10. Gas detection systems should be set to alarm as follows.

1. Gas release alarm (TLV level for toxic gases and 25% of LEL for flammable gases)- Activate building fire alarm system (at least horns and strobes, but there may be flexibility with smoke fans such as with Biodesign).
2. Gas warning alarm (1/2 of TLV for toxics and 5% of LEL for flammables) – send trouble signal to fire alarm panel and/or ASU PD (security company for some leases) to contact lab or EHS oncall representative to investigate.
3. Gas monitor trouble alarm, same as number 2 above.

Alarm set points must be communicated to the Campus Fire Marshal's Office. As the authority having jurisdiction, additional guidance or higher alarm levels may be approved on a case by case basis.

## Oxygen

Normal oxygen levels range between 19.5 and 20.8%. Serious health effects, or death by asphyxiation can occur quickly when oxygen levels are unsafe (below 16%) or fires (above 21%). Liquefied cryogenics and inert gases can displace oxygen and create low oxygen levels in confined spaces or poorly ventilated areas.

Many sources of liquid cryogenics and inert gas exist in teaching and research facilities, including MRI or NMR magnets, cylinders of carbon dioxide, helium, argon and nitrogen, anaerobic incubators, -80°C freezers, and analytical instruments.

Cylinder, tank and dewar failures, magnet quenches or sudden releases from pressure relief valves can overwhelm standard ventilation systems. In most research environments, gas volumes are limited and potentially asphyxiating gases quickly dissipate. Air exchange rates in many labs are relatively high (6-15 ACH) further minimizing the risk of low oxygen levels. Cryogen tanks and compressed gas systems are designed as "fail safe," venting slowly rather than rupturing.

All of these features reduce the need for detection equipment. However, rooms or spaces containing inert gas or other sources of oxygen depletion should be evaluated by an industrial hygienist, and if warranted, safeguards to protect users and those potentially entering these spaces added. When this evaluation indicates, an oxygen monitoring device shall be a first measure and installed in indoor locations where compressed gases or cryogenic liquids are stored and dispensed in a manner that could create the potential for the displacement of oxygen that could present an asphyxiation hazard to occupants.

At a minimum, the following factors should be used in determining if a device should be installed: manufacturer (e.g., magnet) guidance, volume of gas used, location of gas, device safety features, device failure probability, and air changes/hour in the room/area. In particular, [the 2008 NIH DRM](#) notes that both "**carbon dioxide manifold room and nitrogen holding rooms must include oxygen level monitoring alarms**" (section 8, pages 8-80). Additionally, compressed gases or cryogenic liquids shall not be located or dispensed in any indoor location that does not have proper ventilation as determined by an industrial hygienist (sufficient to prevent oxygen levels from falling below 19.5 %).

The installation of the oxygen monitoring device will rely on the manufacturer's specific requirements and the following recommendations. Some of these requirements may include, but not be limited to the following:

1. Oxygen monitors are required in locations where simple asphyxiants and cryogenic liquids are used in locations where catastrophic release will clearly lower oxygen levels below 19.5% by volume, or where operations involving the generation or release of oxygen may produce an atmosphere in excess of 23.5% by volume.
2. Installing the device close to an area where a leak would most likely occur. Sensor(s) for monitors will be installed in locations that are either typical breathing zone height (approximately 4.5 feet above the floor) or other location considered to be representative of room air. In locations where

there is no or limited mechanical ventilation with gases heavier than air the sensor may be installed just above floor level.

3. Ensuring the device's display is accessible; and Alarms are to be local only with signage identifying what actions to take if an alarm or warning strobe is activated. This must include instructions on notifying building support staff, ASU PD and/or EHS.
4. Performing a leak test of the oxygen monitoring devices' sample lines, system components, and fittings.
5. EHS will be notified of the installation of each oxygen monitor that will include, the physical location by building and room number (lab registration number), the purpose of the monitor including asphyxiant gases or cryogenics present, the installation date, and the responsible party for maintenance/calibration of the unit.

As per the manufacture's recommendation, a low oxygen alarm shall be installed along with the monitoring device to alert persons in the surrounding area of a hazardous condition. Where applicable, the device shall also be interlocked with an emergency exhaust fan or ventilation system that is located at the monitored location. An alarm will trigger emergency ventilation of the space. Alarms installed during new construction, or building alteration, should include both a blue light inside and outside the room/area and audible warnings to notify occupants. The alarm location will be specified during the permit review or Prior Approval Process.

OSHA specifies that a hazardous atmosphere may include one where the oxygen concentration is below 19.5% or above 23.5%. The device alarm and warning levels should be set according to these oxygen concentration levels, a normal atmosphere is composed of approximately 21% oxygen and 79% nitrogen.

### **Maintenance and use**

Any maintenance or repair on the monitoring device should be only performed by the manufacturer or manufacturer's representative using manufacturer specific replacement parts, or by personnel authorized and trained to conduct maintenance and repair by either department management or EHS. Most oxygen monitoring devices require minimal periodic maintenance. Follow the manufacturer's recommendations on calibration, maintenance, and sensor replacement.

The installation, testing and maintenance costs for oxygen monitors and associated engineering controls shall be the responsibility of the department or responsibility center using cryogenics or asphyxiant gases.





**Notes:**

Specialty Gas Use and Handling

1. Not required if all cylinders used in exhausted gas cabinets or in a designated hot work area.

T-Toxic

HT= Highly toxic

C-Corrosive

F-Flammable

Pyro- Pyrophoric

H5 - High Hazard Semiconductor Manufacturing

IDLH — Immediately Dangerous to Life And Health. Level of IDLH enforced may differ with the fire authority having jurisdiction. Investigate before using these numbers for your operation.

Rec – Recommended

LEL — Lower Explosive Limit (%) UEL — Upper Explosive Limit (%)

ppm — parts per million concentration

C\*- Ceiling — level not to be exceeded during the workday

\*1 — monitoring may be required depending on use and circumstances. See EHS Department.

NA — Not Applicable

NE — Not Established

## Appendix F

### Gas Cabinets

Gas cabinets are required for the use of any amount of toxic, highly toxic, corrosive, flammable or pyrophoric gas at ASU except where quantities of toxic, corrosives or flammable gases are in cylinder sizes of 40 cubic feet or smaller and where quantities of highly toxic or pyrophoric gases are lecture bottle size only. The gas cabinet is designed to contain and exhaust to a safe location any accidental releases and protect the gas cylinder from physical damage.

A gas cabinet may also be used when the maximum allowable quantity of a gas in a control area exceeds Fire Code limits. In this case, a gas cabinet may allow doubling of the allowable quantity of gas in use.

### Selection

Gas cabinets are often manufactured for the highest level of hazard, need for purity and automation. A gas cabinet with a small cylinder, used intermittently and in small quantities, with minimal purity concerns could be similar to that specified in Figure 1. A gas cabinet for a highly toxic or pyrophoric gas requiring high purity will require a higher level of control as specified in Figure 2.

Figure 1 describes the basic gas cabinet construction requirements.

### Gas panel

The gas panel or manifold is an assembly of gas piping, regulators, and devices designed to safely dispense gas at controlled flow rates. The gas panel is constructed with mechanical fittings, all of which must be kept within the exhausted gas cabinet enclosure. There can be no mechanical connections on systems containing hazardous gases unless they are in an exhausted enclosure except for purge cylinders. Figure 1 presents a simple gas panel with purge capabilities - minimum required for all toxic, highly toxic and pyrophoric gases.

### Local exhaust ventilation

Gas cabinets will require connection to an exhaust system. The manufacturer determines the amount of local exhaust ventilation required to operate the cabinet. Per Chapter 60 of the International Fire Code (IFC), the minimum average face velocity shall not be less than 200 feet per minute (fpm) or 150 fpm at any point across the access port. For a single cylinder cabinet, this usually equates to a volumetric flow rate of 150 cubic feet per minute (cfm). Most manufacturers will require at least 200 cfm and some may require 300 cfm, or more, depending on the cabinet size. Valve manifold boxes, purifier cabinets, and equipment panel cabinets should be exhausted to four to five air changes per minute.

The ductwork materials used must be compatible with the intended gases (e.g., galvanized steel versus stainless steel) and shall not be made from a combustible material. The duct installation shall include an exhaust controlling device – preferably a blast gate.

The blast gate should be located as far away from the cabinet as possible while still being before any upstream branch within the same workspace so that it can be easily accessed. Refer to NFPA 92.

The standard size exhaust connection from a gas cabinet is six inches. The exhaust air shall not be re-circulated into occupied spaces but rather exhausted to the roof in a manner protective of both people working on the roof and those walking nearby. In addition, for toxic and highly toxic gases, a calculation will need to be performed to determine if, in a realistic worst-case release of gas, the concentration of the gas is less than  $\frac{1}{2}$  the immediately dangerous to life and health (IDLH) concentration. These requirements may drive the need for an air-scrubbing device and/or restricted flow orifice (see Treatment Systems). Furthermore, the exhaust shall not be located such that it could result in re-entrainment of the contaminant into occupied spaces through doors, windows, or HVAC air intakes.

Cabinet exhaust inlet and outlet shall be designed for good sweep through the entire volume. The inlet louver should have adjustability to aid in balancing the exhaust and achieving required static pressure in the cabinet and duct.

### **Gas cabinet installation**

After gas cabinet selection and before purchase, approval must be obtained from EHS and the Fire Marshal's Office (FMO).

### **Location**

Gas cabinets for hazardous gases should not be installed outdoors, unless physically secured behind locked fencing or walls and never near a public way. Unless under direct control of users, gas cabinet areas should be limited to authorized employees only. Gas cabinets cannot be stored in hallways used for exit access. Avoid placing cabinets in any heavy traffic areas which would restrict gas cylinder changes.

### **Treatment system**

For Toxic and Highly Toxic gases, a treatment system will be installed to handle an accidental release of a full cylinder of gas and reduce the maximum allowable discharge concentrations to one half immediately dangerous to life and health (IDLH) concentrations at the point of discharge to atmosphere. If the cylinder is equipped with a restrictive flow orifice (RFO), the release rate will be calculated by the maximum flow from the valve as determined by the manufacturer. If not equipped with a RFO, release rate will be considered 5 minutes for non-liquified gases and 30 minutes for a liquified gas.

For Toxic gases, a treatment system is not required when an approved gas detection system and approved automatic-closing fail-safe valve is located immediately adjacent to the cylinder valve.

## **Purge and Vacuum Venturi Vent Gas**

An inert gas must be supplied to the gas cabinet for Toxic, Highly Toxic and Pyrophoric gas panel purging and if present, the vacuum venturi vent. A mixture of 10% Helium/90% Nitrogen is recommended for the purge gas to facilitate leak checking of the system.

The purge gas supply must be at least 85 psi for cycle purging. The venturi vent is used to pull a vacuum on the panel and ensure an inert atmosphere in pyrophoric vent lines. Purge gases cannot be shared between incompatible hazardous gases (e.g., an oxidizer and a flammable). Panel purge gases shall be delivered from a cylinder source and not from house nitrogen or other house gases. Venturi vent gas typically uses a house nitrogen source.

## **Automatic Sprinkler**

A gas cabinet containing a hazardous gas, located in an occupancy area, must have fire suppression and detection in the form of a wax coated sprinkler head to be connected to facility automatic sprinkler system. This is not required if the gas cabinet is in an approved gas distribution room or outdoors.

## **Operation**

Standard operating procedures (SOPs) must be developed before operation and approved by EHS and FMO. These must detail the safe operation procedures of the gas cabinet. At a minimum, these procedures shall address the following:

- Installation, removal, and securing of gas cylinders inside the cabinet.
- Maintenance requirements, including calibration of gas detection equipment and ventilation checks.
- Purging of the manifold.
- Response to alarm activation.

**Figure 1**

### Gas Cabinet Specification with Minimum Purge Capability

**Gas cabinet** – designed to provide an exhausted enclosure for gas cylinders. Required for all toxic, highly toxic, flammable and pyrophoric gas cylinders. Must meet the following:

1. Constructed of 12-gauge steel.
2. Be provided with self-closing limited access ports or windows to give access to controls, when feasible.
3. Self-closing doors.
4. Treated, coated or constructed of materials compatible with materials stored.
5. Exhaust ventilation to provide an average of 200 linear feet per minute across any open access port with no reading less than 150 lfpm.
6. Purge panel for evacuating and venting gases from process lines for corrosive, toxic and highly toxic gases and pyrophoric gases.
7. When required, accept the output of hazardous gas monitors such that upon detection of a leak the controller will enact a shut off flow of gas, and provide indication via a local visual and audible alarm.
8. An EMO must be hard wired to the respective unit and can trigger cylinder shutdown and indicate via a visual and audible alarm.
9. Fire detection for pyrophoric gases.
10. Exhaust flow monitoring.
11. Fire suppression and detection in the form of a wax coated sprinkler head to be connected to facility automatic sprinkler system.

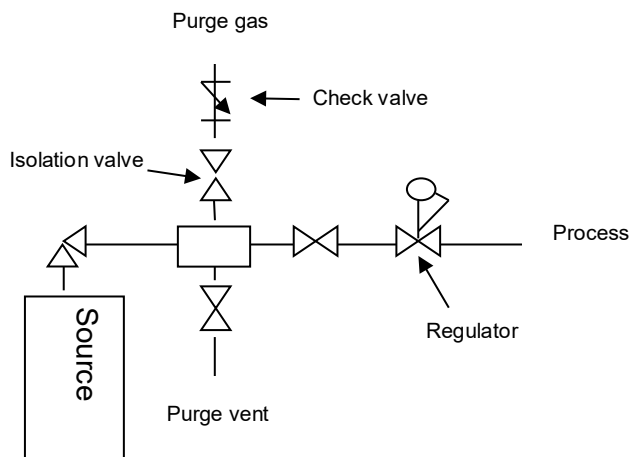

## Figure 2

### Gas Cabinet with Control Panel Specification

**Gas cabinet** – designed to provide an exhausted enclosure for gas cylinders.

1. Constructed of 12 gauge steel.
2. Be provided with self-closing limited access ports or windows to give access to controls, when feasible.
3. Self closing doors.
4. Treated, coated or constructed of materials compatible with materials stored.
5. Exhaust ventilation to provide an average of 200 linear feet per minute with no reading less than 150 lfpm across any open access port.
6. Purge panel for evacuating and venting gases from process lines for corrosive, toxic and highly toxic gases and pyrophoric gases.
7. When required, accept the output of hazardous gas monitors such that upon detection of a leak the controller will enact a shut off flow of gas, and provide indication via a local visual and audible alarm.
8. An EMO must be hard wired to the respective unit and can trigger cylinder shutdown and indicate via a visual and audible alarm.
9. Fire detection for pyrophoric gases.
10. Exhaust flow monitoring.
11. Fire suppression and detection in the form of a wax coated sprinkler head to be connected to facility automatic sprinkler system.
12. Excess flow valve.
13. Downstream High-Pressure Sensor - when pressure exceeding safe levels is detected, panel vents the system
14. Vacuum Generator Module – Creates the vacuum necessary for safe operation of the gas system. Includes:
  1. Vacuum Venturi capable of 100 Torr.
  2. Check Valve to prevent back-flow of process gas into the house N2 system.
  3. Isolation Valve to control flow of house vacuum to the Venturi.
15. Pneumatic Cylinder Isolation Valve– Cylinders can be ordered with a pneumatic cylinder valve in place of the standard manual valve. Typically used with Toxic, Highly Toxic and Pyrophoric gases. A controller will be configured with extra solenoid valves and programming to use pneumatic pressure to open the cylinder to process. Should there be a fault condition requiring shutdown of the cabinet, i.e., leak detection, fire, power outage, EMO, etc. activation the air to this valve is shut and the valve at the gas source closes.
16. Auto-Crossover Functions – The controller allows for a pressure input letting the system know when a cylinder needs to be changed. An alarm will sound for low cylinder pressure. When the cylinder pressure falls to this set pressure, the valve on the delivery panel will close and the valve on the backup panel will open ensuring the constant supply of gas. When the spent cylinder is replaced, it will serve as the backup for the current cylinder in use.

17. Scales may be needed to quantify usage and monitor the amount of liquid in cylinders.

## Controller

To automatically monitor and control the operation of the gas cabinet, a controller is needed. The controller is normally anchored to the top of the cabinet and comes with a standard set of inputs and outputs. Controllers must have an emergency shutoff button, a local audible alarm, a local visual alarm, and pneumatic connections for input and output for emergency shut off valve control.

Typical controller sensors and shutdowns include:

- Excess Flow
- Exhaust Fail
- Fire Detection
- Gas Detector Alarm
- Gas Detector Warning
- Hi Delivery Pressure.

**Pneumatic gas** – for operation of panel automatic valves - typically 75 psi. Use inert gas in flammable and pyrophoric gas cabinets.

